

TRANSIENT PROTECTION FOR +7V RAIL

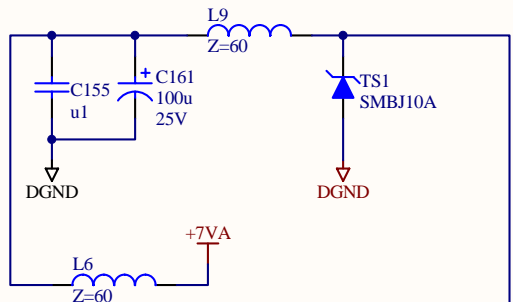

- D1 Row D
- D2 Row D
- D3 Row D
- D4 Row D
- D5 Row D
- D6 Row D
- D7 Row D
- D8 Row D
- D9 Row D
- D10 Row D
- D11 Row D
- D12 Row D
- D13 Row D
- D14 Row D
- D15 Row D
- D16 Row D
- D17 Row D
- D18 Row D
- D19 Row D
- D20 Row D
- D21 Row D
- D22 Row D
- D23 Row D
- D24 Row D

- C1 Row C
- C2 Row C
- C3 Row C
- C4 Row C
- C5 Row C
- C6 Row C
- C7 Row C
- C8 Row C
- C9 Row C
- C10 Row C
- C11 Row C
- C12 Row C
- C13 Row C
- C14 Row C
- C15 Row C
- C16 Row C
- C17 Row C
- C18 Row C
- C19 Row C
- C20 Row C
- C21 Row C
- C22 Row C
- C23 Row C
- C24 Row C

- B1 Row B
- B2 Row B
- B3 Row B
- B4 Row B
- B5 Row B
- B6 Row B
- B7 Row B
- B8 Row B
- B9 Row B
- B10 Row B
- B11 Row B
- B12 Row B
- B13 Row B
- B14 Row B
- B15 Row B
- B16 Row B
- B17 Row B
- B18 Row B
- B19 Row B
- B20 Row B
- B21 Row B
- B22 Row B
- B23 Row B
- B24 Row B

- A1 Row A
- A2 Row A
- A3 Row A
- A4 Row A
- A5 Row A
- A6 Row A
- A7 Row A
- A8 Row A
- A9 Row A
- A10 Row A
- A11 Row A
- A12 Row A
- A13 Row A
- A14 Row A
- A15 Row A
- A16 Row A
- A17 Row A
- A18 Row A
- A19 Row A
- A20 Row A
- A21 Row A
- A22 Row A
- A23 Row A
- A24 Row A

J1D

J1C

J1B

J1A

Clock Card - Slot 8

CONFIGURATION READY INTERFACE

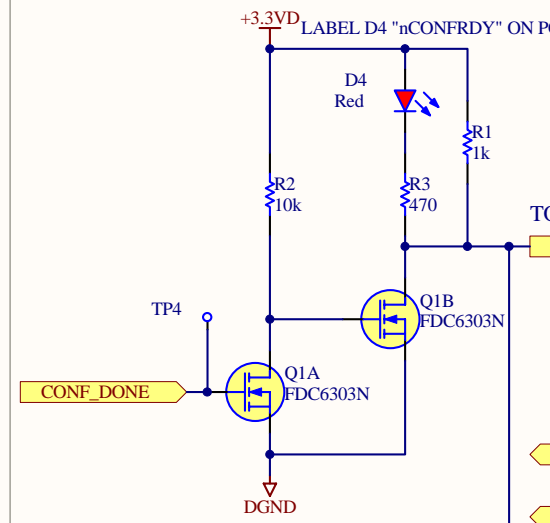

- D1 Row D
- D2 Row D
- D3 Row D
- D4 Row D
- D5 Row D
- D6 Row D
- D7 Row D
- D8 Row D
- D9 Row D
- D10 Row D
- D11 Row D
- D12 Row D
- D13 Row D
- D14 Row D
- D15 Row D
- D16 Row D
- D17 Row D
- D18 Row D
- D19 Row D
- D20 Row D
- D21 Row D
- D22 Row D
- D23 Row D
- D24 Row D
- D25 Row D
- D26 Row D
- D27 Row D
- D28 Row D
- D29 Row D
- D30 Row D
- D31 Row D
- D32 Row D
- D33 Row D
- D34 Row D
- D35 Row D
- D36 Row D
- D37 Row D
- D38 Row D
- D39 Row D
- D40 Row D
- D41 Row D
- D42 Row D
- D43 Row D
- D44 Row D
- D45 Row D
- D46 Row D
- D47 Row D
- D48 Row D

- C1 Row C
- C2 Row C
- C3 Row C
- C4 Row C
- C5 Row C
- C6 Row C
- C7 Row C
- C8 Row C
- C9 Row C
- C10 Row C
- C11 Row C
- C12 Row C
- C13 Row C
- C14 Row C
- C15 Row C
- C16 Row C
- C17 Row C
- C18 Row C
- C19 Row C
- C20 Row C
- C21 Row C
- C22 Row C
- C23 Row C
- C24 Row C
- C25 Row C
- C26 Row C
- C27 Row C
- C28 Row C
- C29 Row C
- C30 Row C
- C31 Row C
- C32 Row C
- C33 Row C
- C34 Row C
- C35 Row C
- C36 Row C
- C37 Row C
- C38 Row C
- C39 Row C
- C40 Row C
- C41 Row C
- C42 Row C
- C43 Row C
- C44 Row C
- C45 Row C
- C46 Row C
- C47 Row C
- C48 Row C

- B1 Row B
- B2 Row B
- B3 Row B
- B4 Row B
- B5 Row B
- B6 Row B
- B7 Row B
- B8 Row B
- B9 Row B
- B10 Row B
- B11 Row B
- B12 Row B
- B13 Row B
- B14 Row B
- B15 Row B
- B16 Row B
- B17 Row B
- B18 Row B
- B19 Row B
- B20 Row B
- B21 Row B
- B22 Row B
- B23 Row B
- B24 Row B
- B25 Row B
- B26 Row B
- B27 Row B
- B28 Row B
- B29 Row B
- B30 Row B
- B31 Row B
- B32 Row B
- B33 Row B
- B34 Row B
- B35 Row B
- B36 Row B
- B37 Row B
- B38 Row B
- B39 Row B
- B40 Row B
- B41 Row B
- B42 Row B
- B43 Row B
- B44 Row B
- B45 Row B
- B46 Row B
- B47 Row B
- B48 Row B

- A1 Row A
- A2 Row A
- A3 Row A
- A4 Row A
- A5 Row A
- A6 Row A
- A7 Row A
- A8 Row A
- A9 Row A
- A10 Row A
- A11 Row A
- A12 Row A
- A13 Row A
- A14 Row A
- A15 Row A
- A16 Row A
- A17 Row A
- A18 Row A
- A19 Row A
- A20 Row A
- A21 Row A
- A22 Row A
- A23 Row A
- A24 Row A
- A25 Row A
- A26 Row A
- A27 Row A
- A28 Row A
- A29 Row A
- A30 Row A
- A31 Row A
- A32 Row A
- A33 Row A
- A34 Row A
- A35 Row A
- A36 Row A
- A37 Row A
- A38 Row A
- A39 Row A
- A40 Row A
- A41 Row A
- A42 Row A
- A43 Row A
- A44 Row A
- A45 Row A
- A46 Row A
- A47 Row A
- A48 Row A

J2D

J2C

J2B

J2A

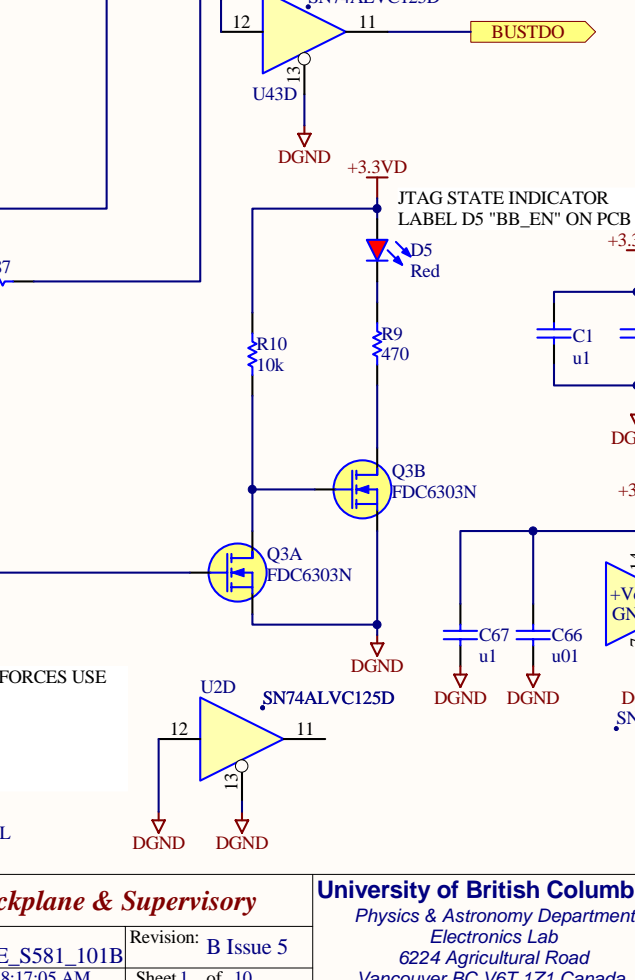
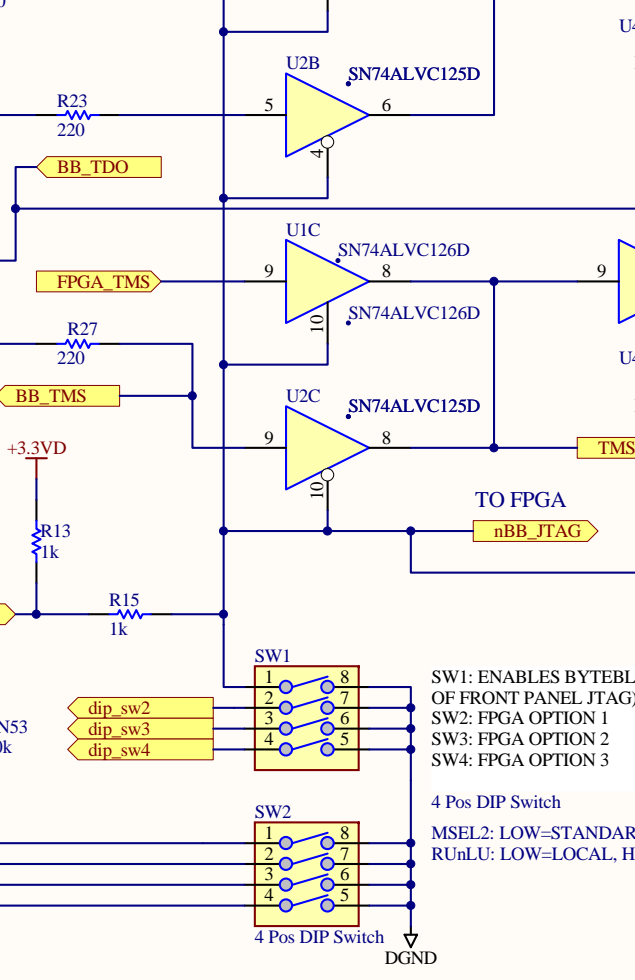
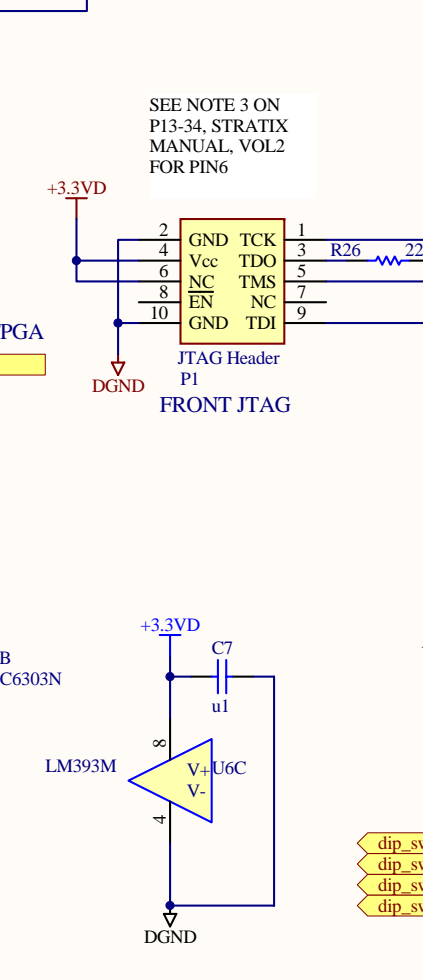
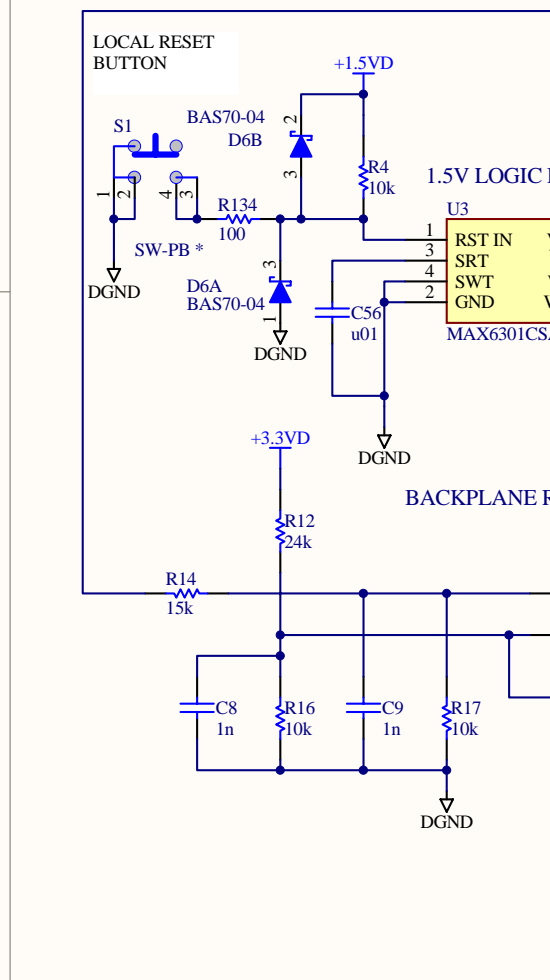
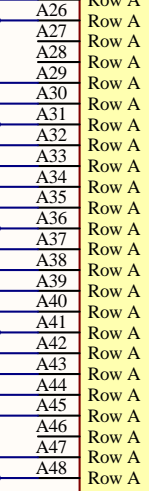
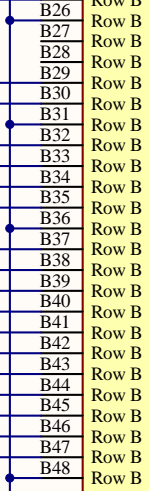
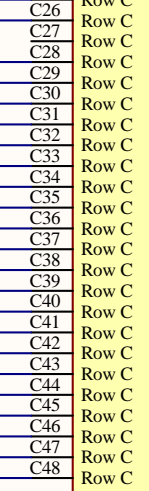
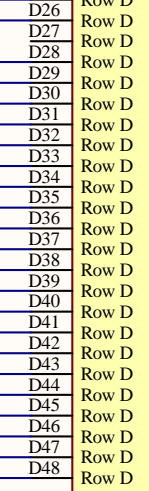
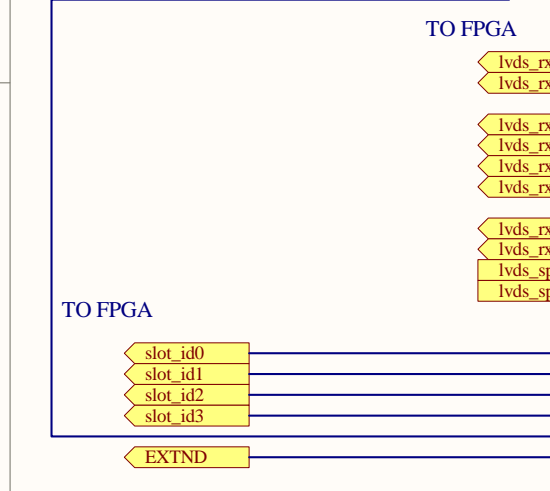

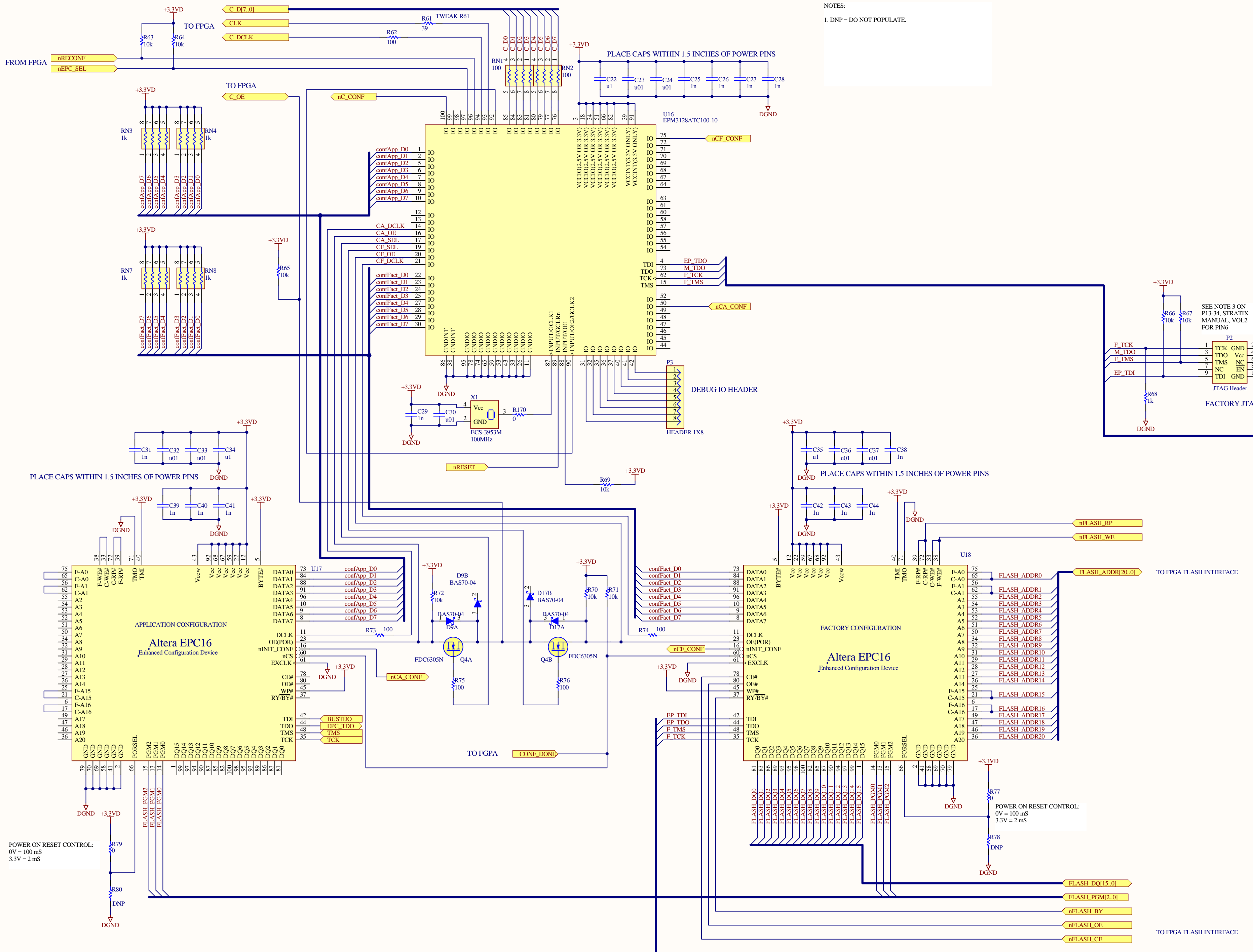

NOTES:
1. DNP = DO NOT POPULATE.

POWER ON RESET CONTROL:
0V = 100 mS
3.3V = 2 mS

POWER ON RESET CONTROL:
0V = 100 mS
3.3V = 2 mS

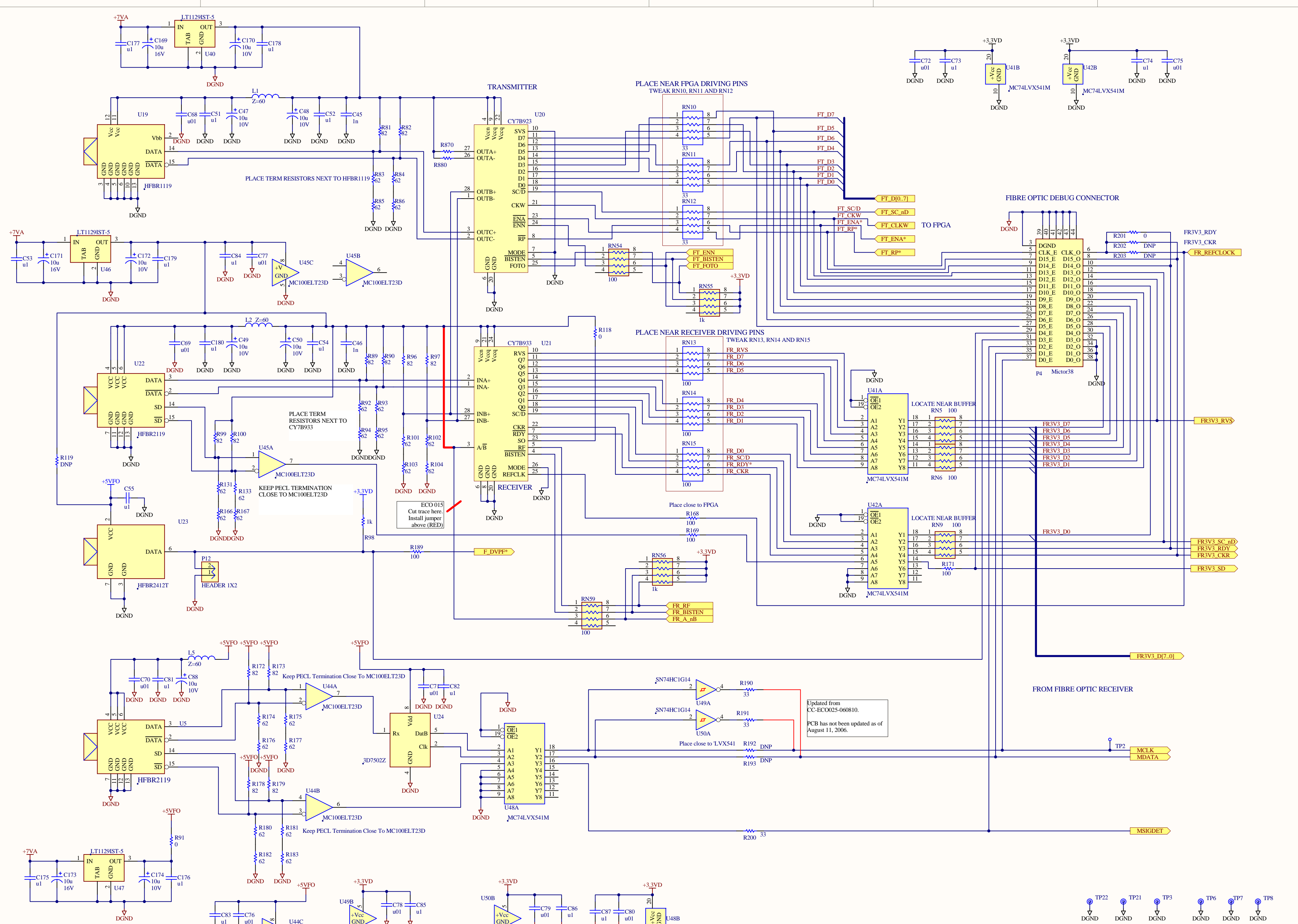

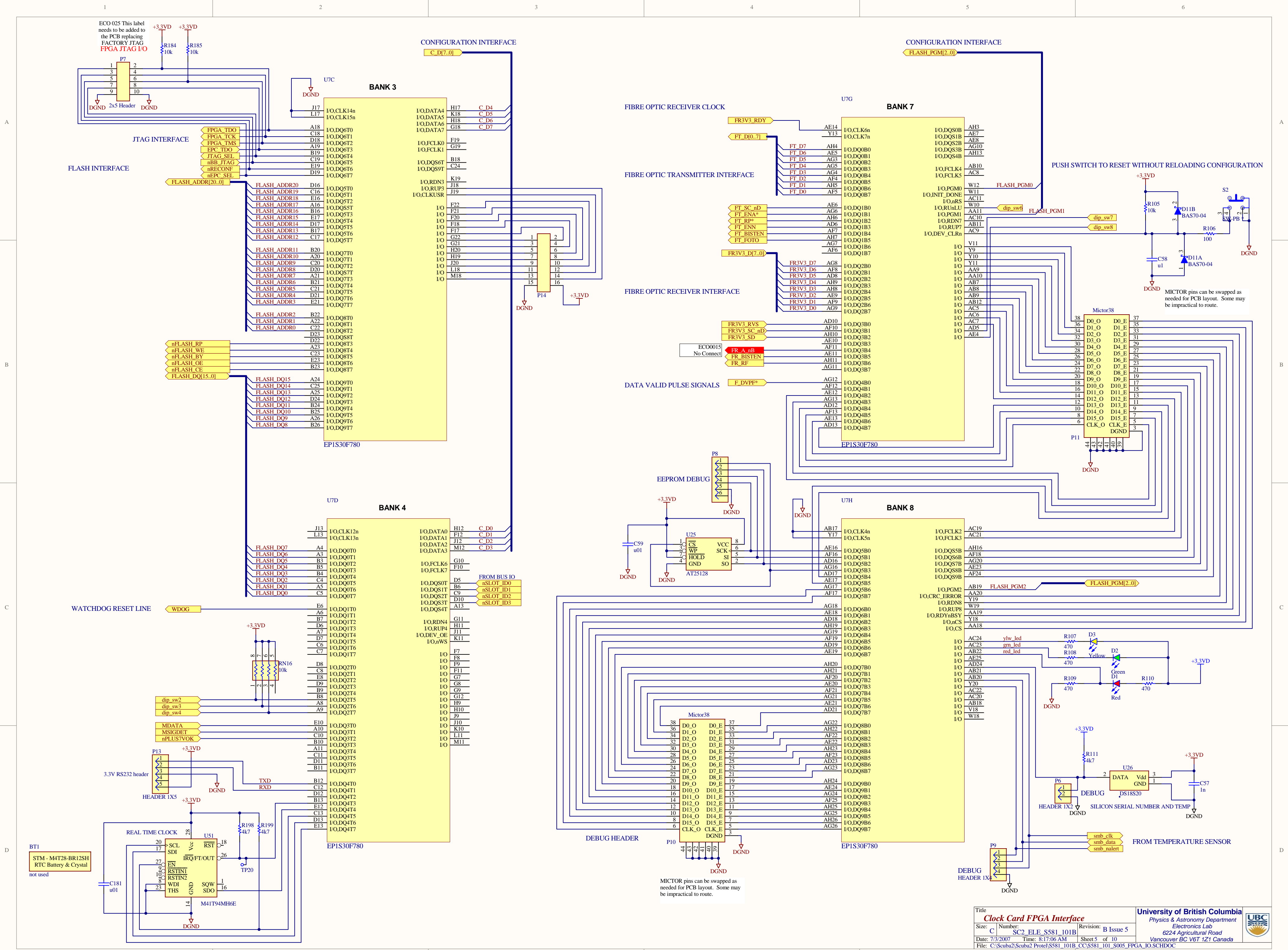

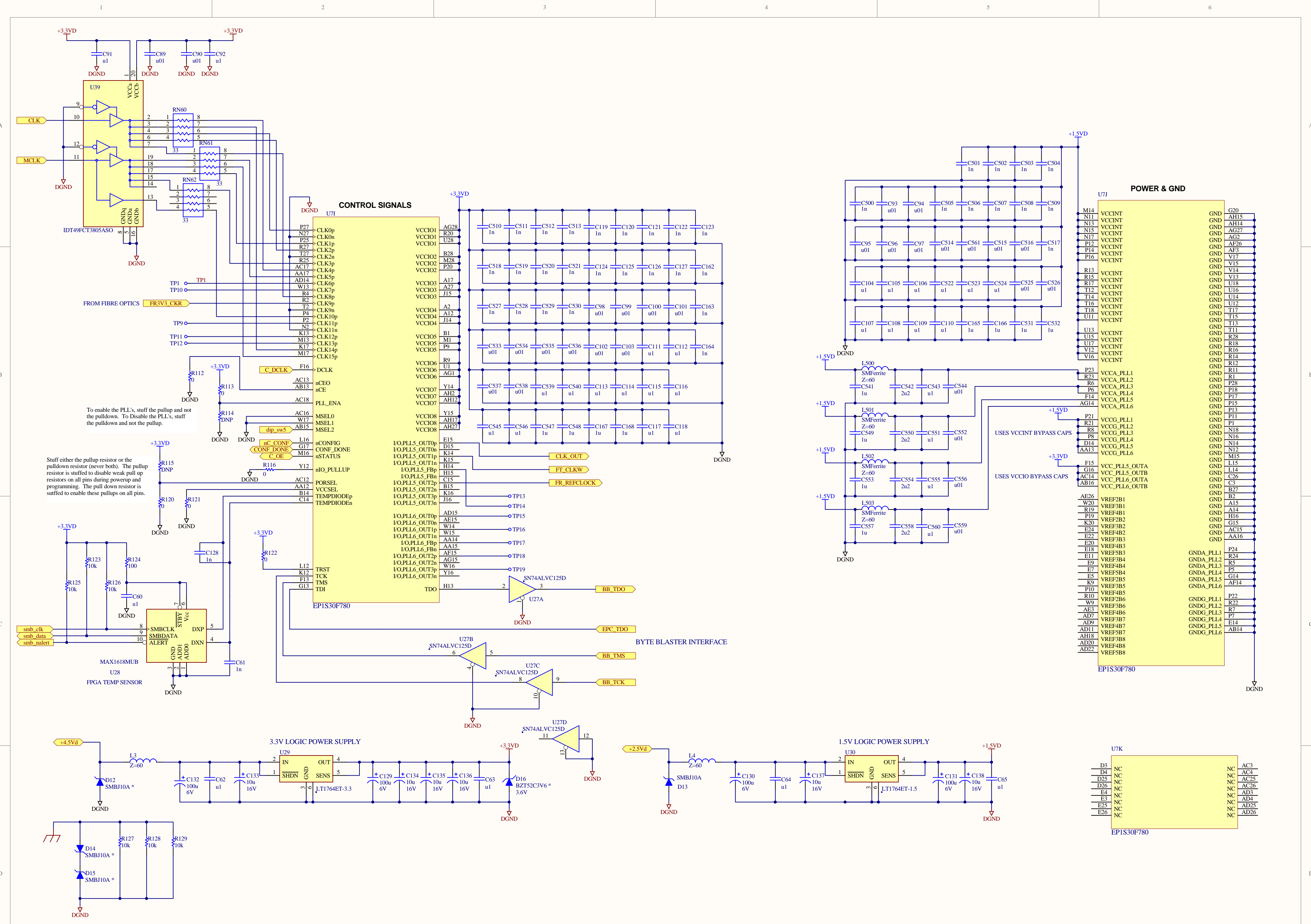

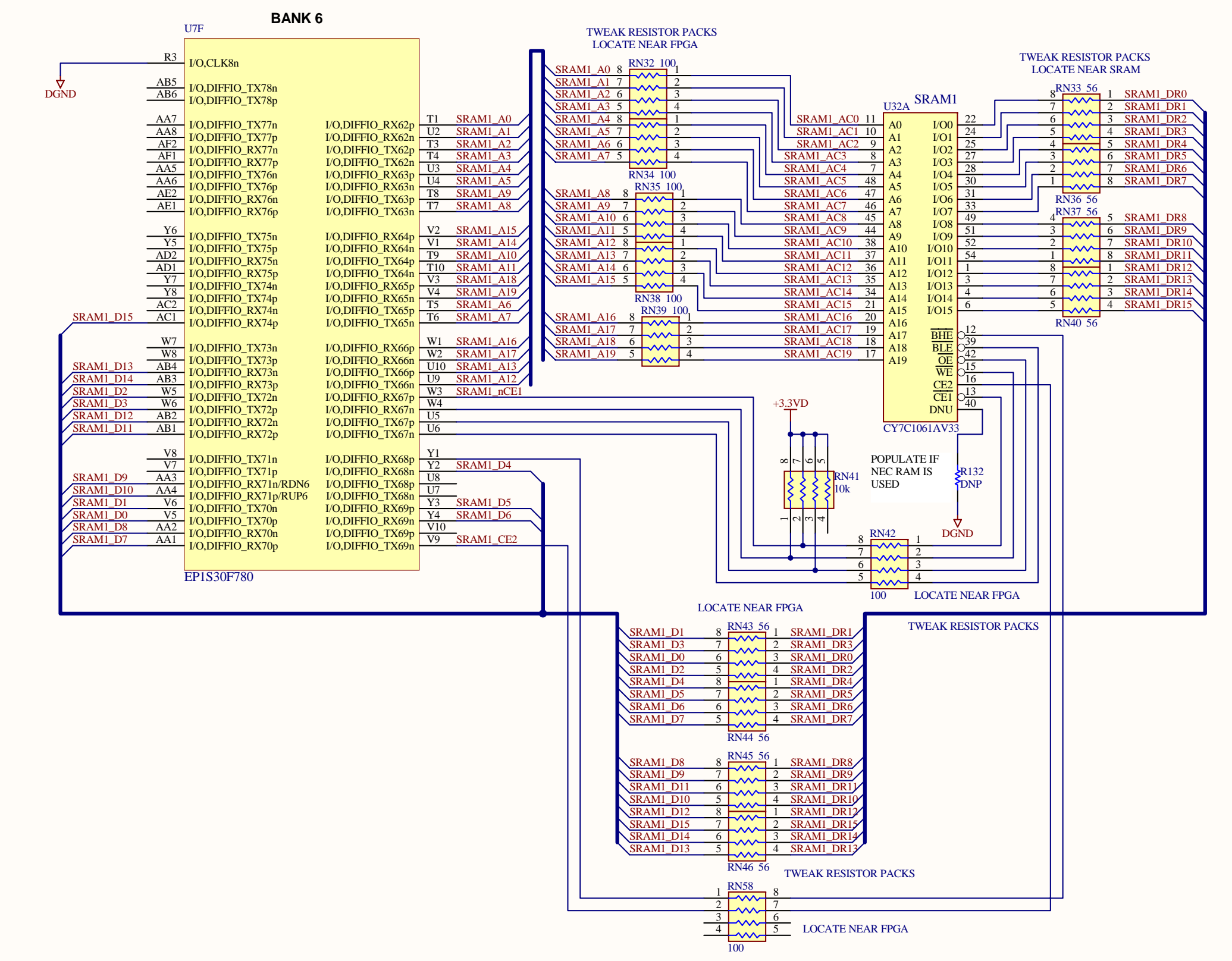
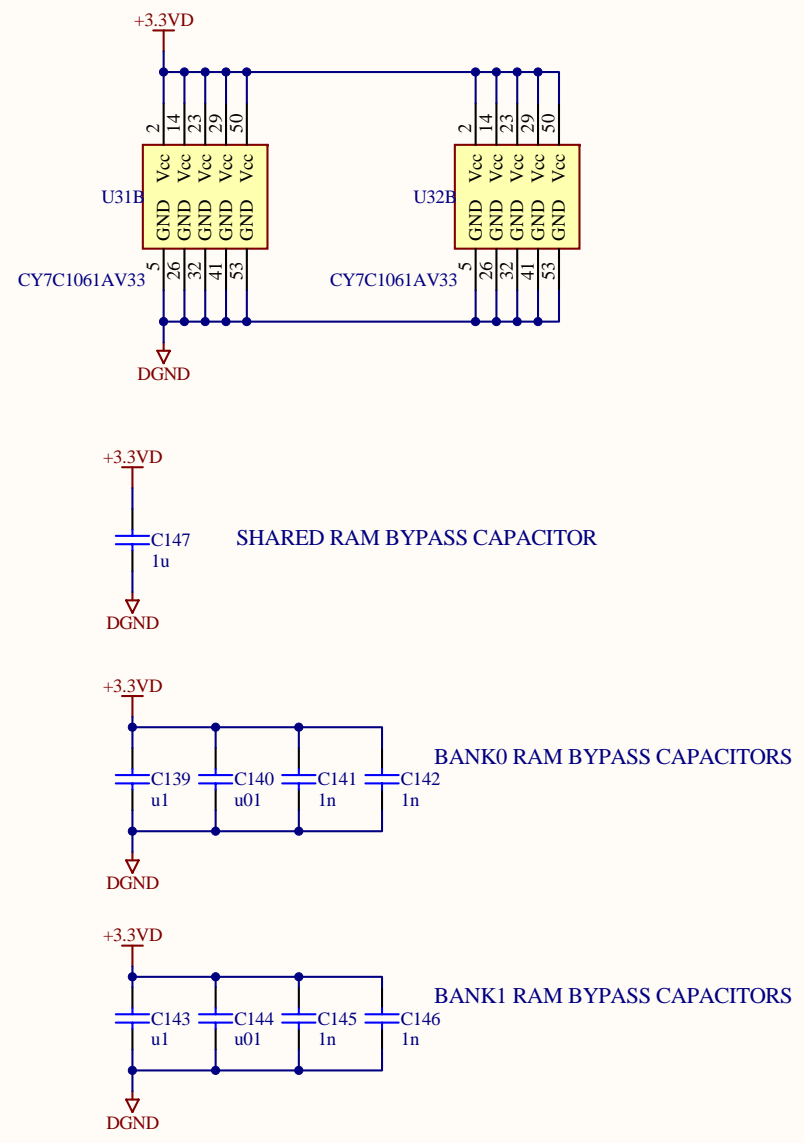
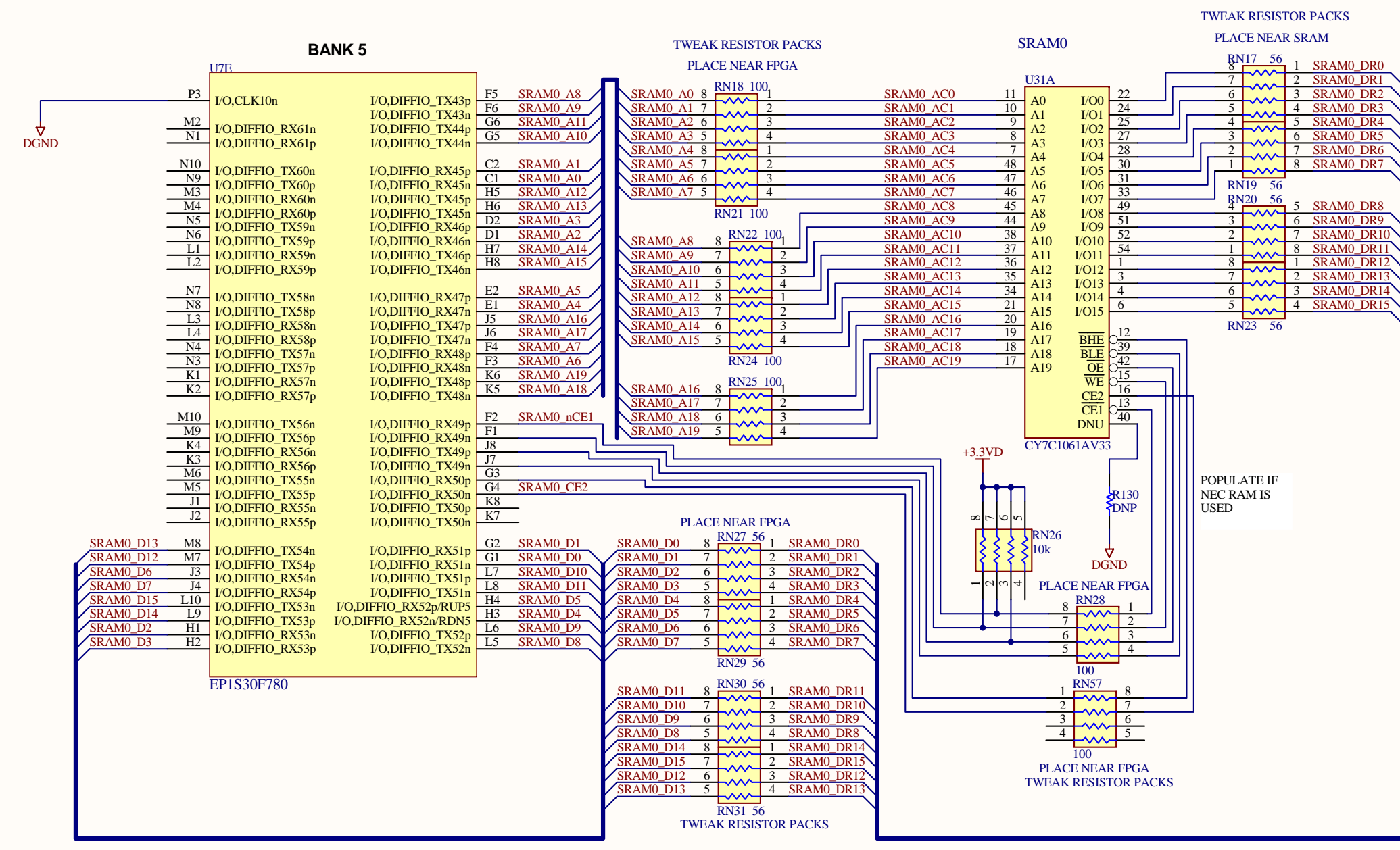

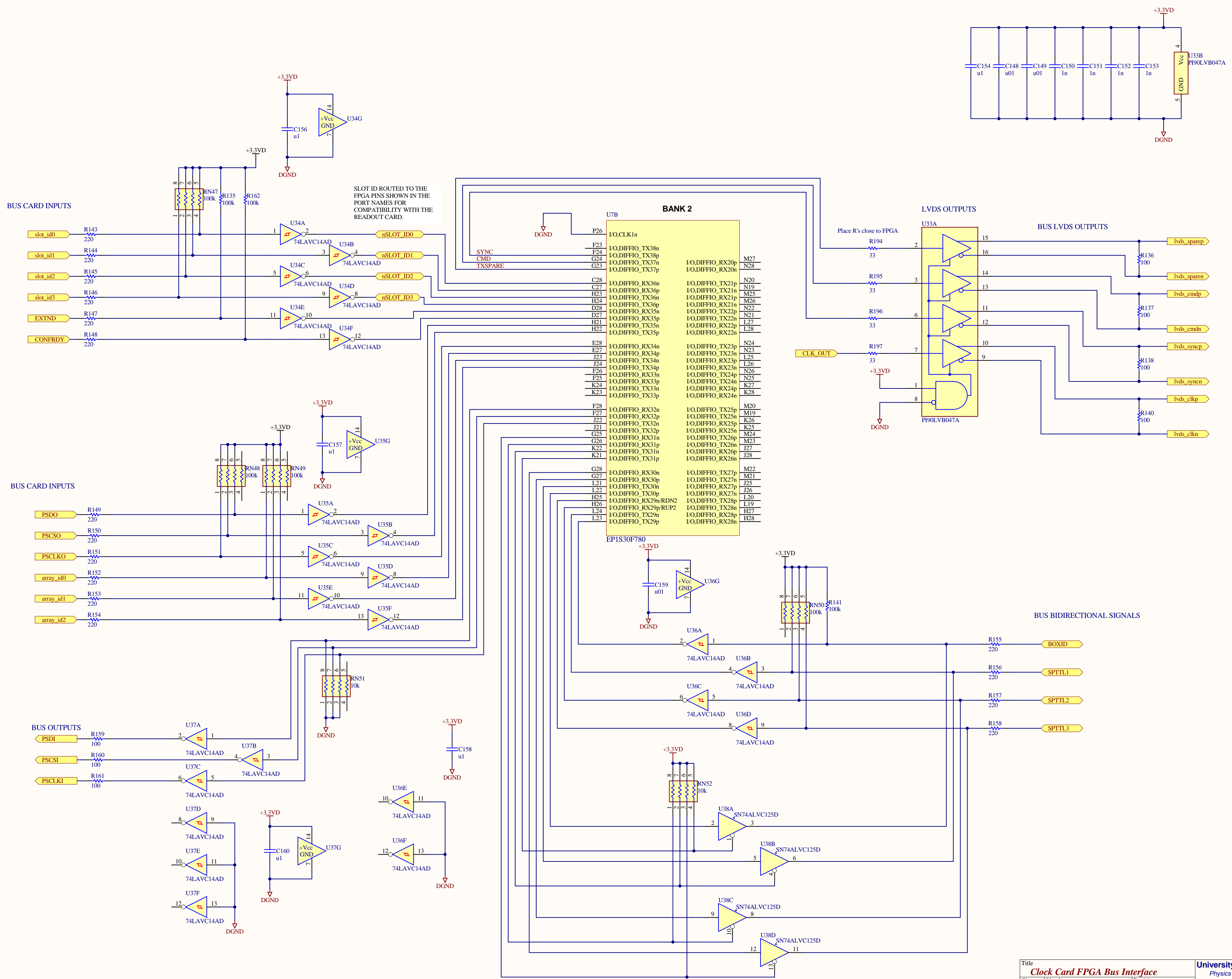

1 2 3 4 5 6

A

A

B

B

C

C

D

D

SHEET 1
S581_101_S001_BUS.SCHDOC

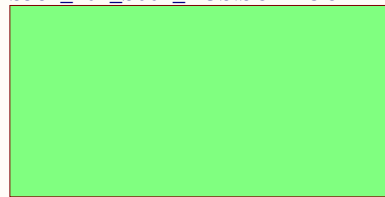

SHEET 4
S581_101_S004_FIBRE_OPTIC.SCHDOC



SHEET 7
S581_101_S007_SRAM.SCHDOC

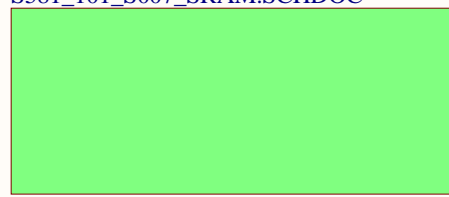

SHEET 2
S581_101_S002_LVDS.SCHDOC

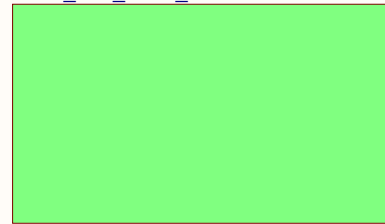

SHEET 5
S581_101_S005_FPGA_IO.SCHDOC



SHEET 8
S581_101_S008_FPGA_BUSIO.SCHDOC



SHEET3
S581_101_S003_CONFIG.SCHDOC

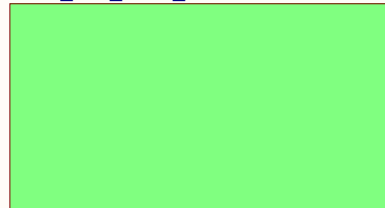

SHEET 6
S581_101_S006_FPGA_PWR.SCHDOC



U_HardwareSheet
S581_101_S009_MECH.SchDoc



Title Clock Card Top Level			University of British Columbia Physics & Astronomy Department Electronics Lab 6224 Agricultural Road Vancouver BC V6T 1Z1 Canada	
Size: B	Number: SC2_ELE_S581_101B	Revision: B Issue 5		
Date: 7/3/2007	Time: 8:17:06 AM	Sheet 9 of 10		
File: C:\Scuba2\Scuba2 Proteh\S581_101B_CC\S581_101_S000_TOP.SCHDOC				

1 2 3 4 5 6

TO-220 Heatsink Assembly

- #6 Flat Washer
Pacific Fastener
Mech1
- #6 Nut
Pacific Fastener
Mech5
- #6 Spring Washer
Manufacturer: Pacific Fastener
Part Number:
Mech9
- #6 x 0.125 Al Spacer
Manufacturer: Pacific Fastener
Part Number:
Mech13
- #6 x 0.75" Philips Pan Head
Manufacturer: Pacific Fastener
Part Number:
Mech17
- 3W TO-220 Heatsink
Manufacturer: Wakefield
Part Number: 273AB
HS1

TO-220 Heatsink Assembly

- #6 Flat Washer
Pacific Fastener
Mech2
- #6 Nut
Pacific Fastener
Mech6
- #6 Spring Washer
Manufacturer: Pacific Fastener
Part Number:
Mech10
- #6 x 0.125 Al Spacer
Manufacturer: Pacific Fastener
Part Number:
Mech14
- #6 x 0.75" Philips Pan Head
Manufacturer: Pacific Fastener
Part Number:
Mech18
- 3W TO-220 Heatsink
Manufacturer: Wakefield
Part Number: 273AB
HS2

Front Panel Mounting Assembly

- Bottom Extraction Handle
Manufacturer: Rittal
Part Number: 3686-902
Mech3
- Top Extraction Handle
Manufacturer: Rittal
Part Number: 3686-903
Mech4
- SCUBA2 Clock Card Front Panel
Manufacturer: PHAS-MS
Part Number: SC2-ELE-S581-110
Mech8
- Mounting Bracket for PCB
Manufacturer: Rittal
Part Number: 3685-198 (10/pack)
Mech11
- Mounting Bracket for PCB
Manufacturer: Rittal
Part Number: 3685-198 (10/pack)
Mech12
- M2.5 x 8mm Machine Screw Cone Head
Type: Hardware
Mech15
- M2.5 x 8mm Machine Screw Cone Head
Type: Hardware
Mech16
- M2.5 x 8mm Machine Screw
Type: Hardware
Mech19
- M2.5 x 8mm Machine Screw
Type: Hardware
Mech20
- M2.5 x 8mm Machine Screw
Type: Hardware
Mech21
- M2.5 x 8mm Machine Screw
Type: Hardware
Mech22

- 16 Pin DIP IC Socket
Manufacturer: Mill-Max
Part Number: 110-93-316-41-001
Socket1
- 16 Pin DIP IC Socket
Manufacturer: Mill-Max
Part Number: 110-93-316-41-001
Socket2
- 16 Pin DIP IC Socket
Manufacturer: Mill-Max
Part Number: 110-93-316-41-001
Socket3

- 8 Pin 2x4 0.1"
Manufacturer: Mill-Max
Socket4
- Note for Socket 4:
8 Pin 2x4 0.1" Header Machined
Pins with manuf # modified from
410-93-210-41-001

M1-M4 are mounting holes
ECO0025 change to free pads on
PCB

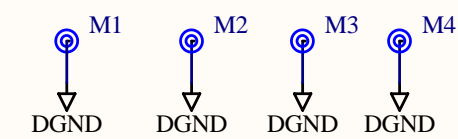

PCB Part Number for BOM:

Title Clock Card Mechanical Hardware		University of British Columbia Physics & Astronomy Department SCUBA2 Project 6224 Agricultural Road Vancouver BC V6T 1Z1 Canada	
Size: B	Number: SC2_ELE_S581_101	Revision: B Issue 5	
Date: 7/3/2007	Time: 8:17:06 AM	Sheet 10 of 10	
File: S581_101_S009_MECH.SchDoc			

