

Bias Card Master Sheet
BC_Interface.SCHDOC:BC_Config.SCHDOC:BC_Heater.SCHDOC:BC_FPGA1.SCHDOC:BC_FPGA2.SCHDOC:BC_Analog.SCHDOC:BC_SA_Htr.SCHDOC

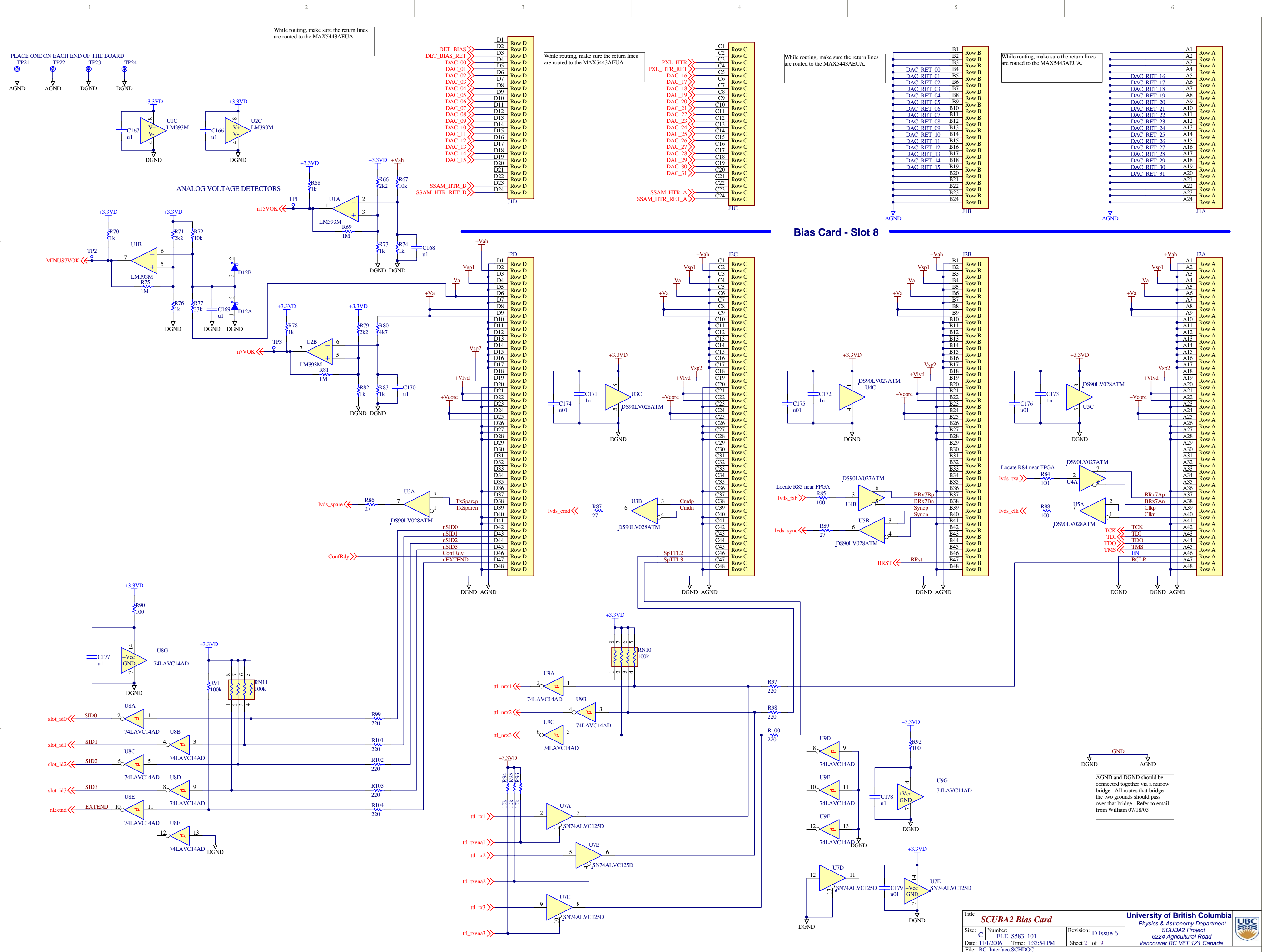

Use UBC Logo
Use UBC Logo

Add Fiducial Point
FP1 Global fiducials should be located in the four corners of the PCB board.
Add Fiducial Point
FP2
Add Fiducial Point
FP3 Fiducials should be at least 3mm from the edge of the board.
Add Fiducial Point
FP4



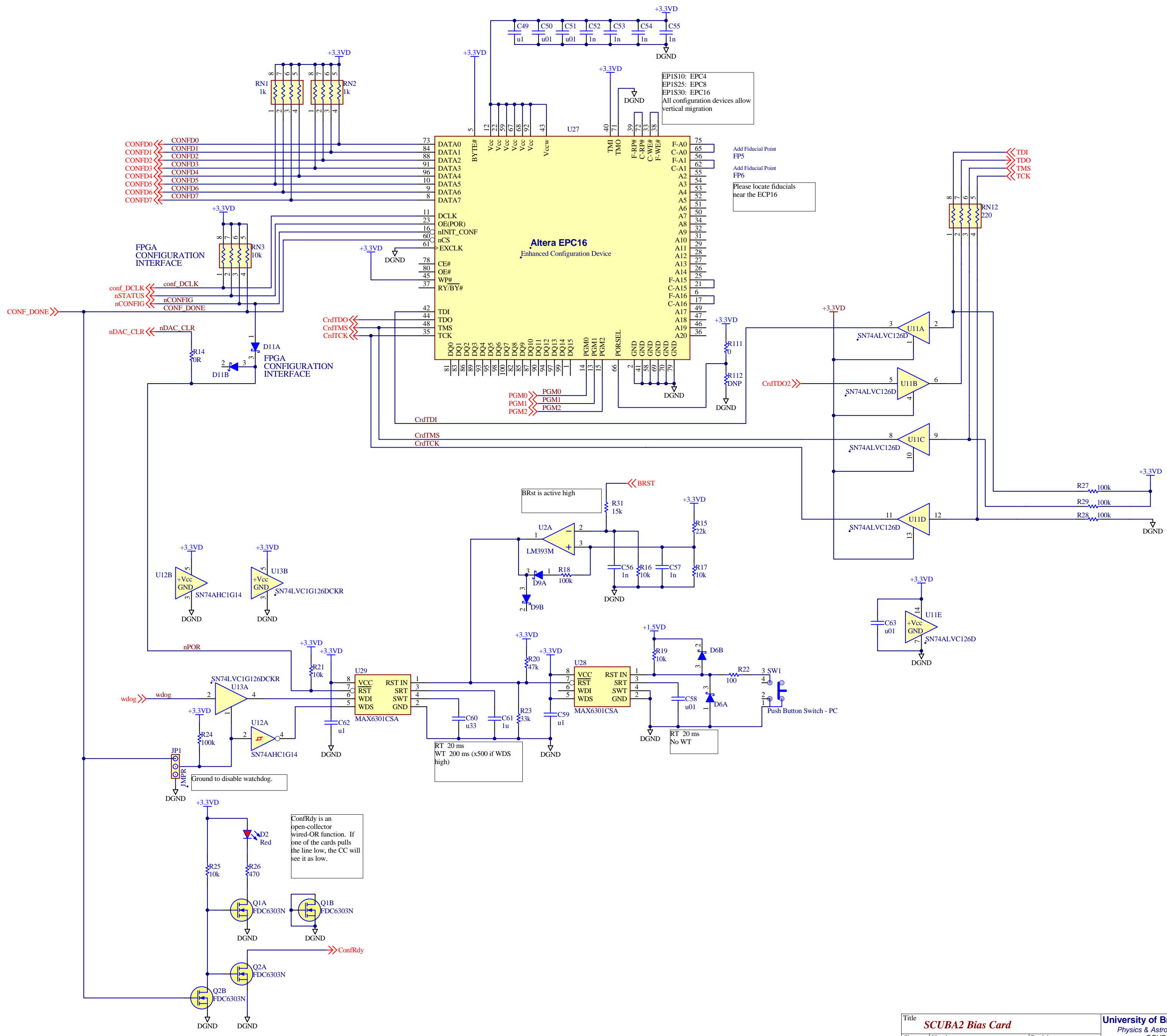

A

A

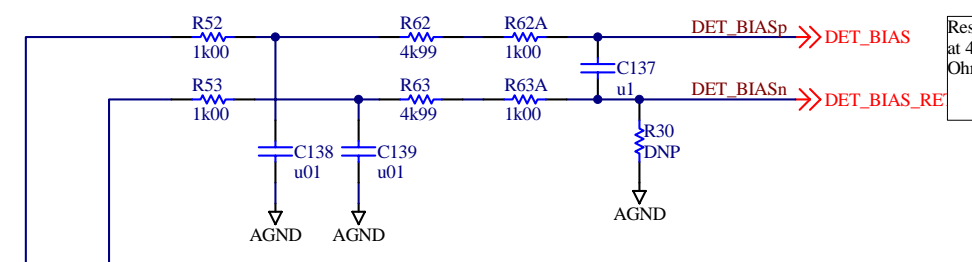
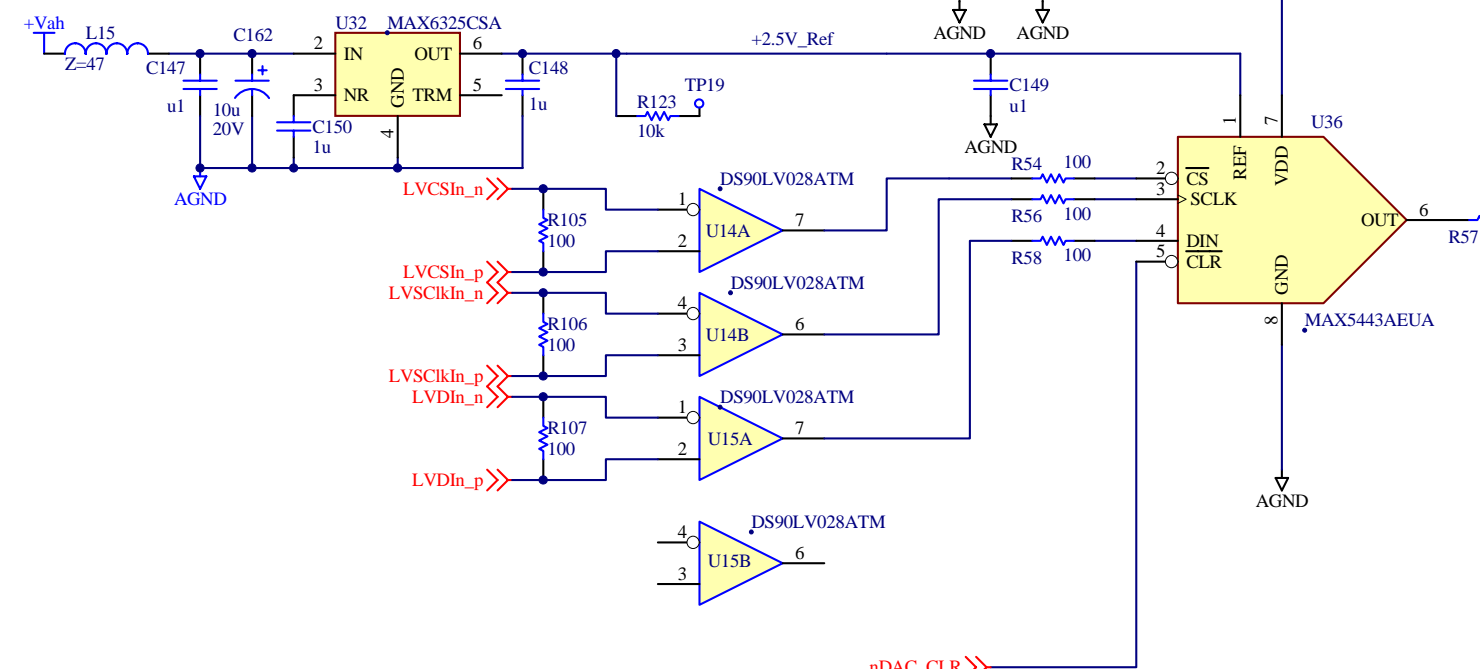
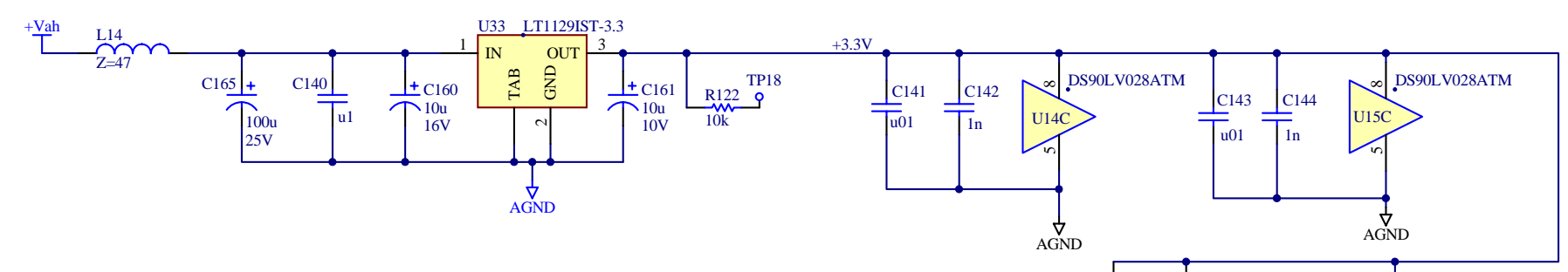
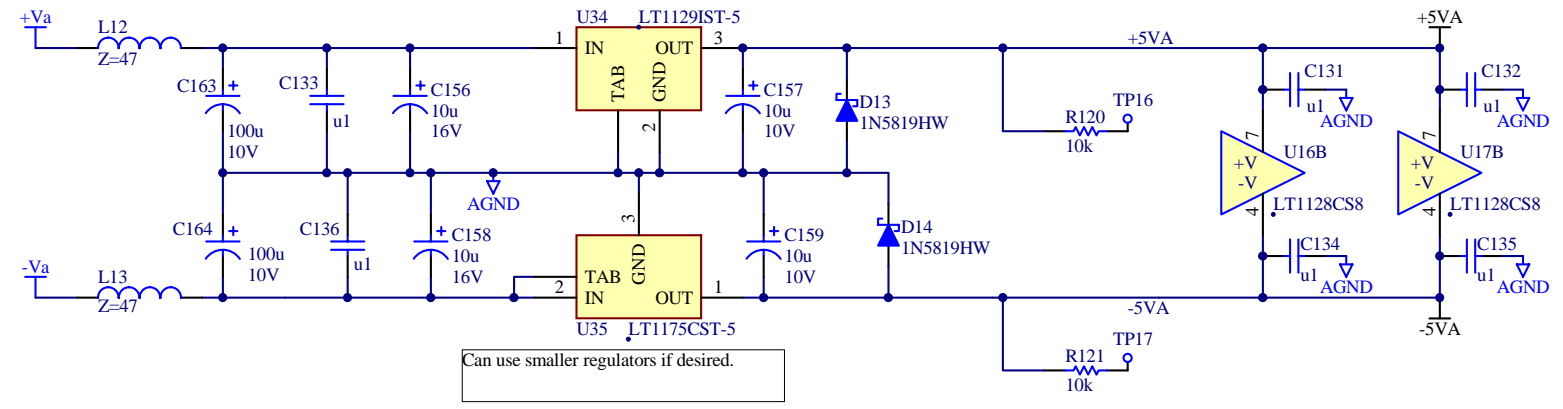

Resistance calculated at 41x32 pixels at 4.4 mOhms/pixel = 5.8 Ohms + 260 Ohm cable

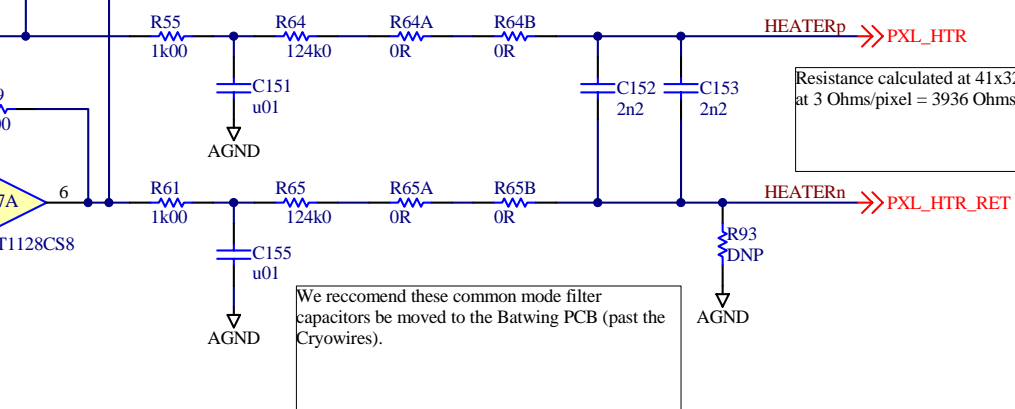

Resistance calculated at 41x32 pixels at 3 Ohms/pixel = 3936 Ohms

We recommend these common mode filter capacitors be moved to the Batwing PCB (past the Cryowires).

B

B

C

C

D

D

