

AC Master Sheet
S584_101_S02_backplane.SCHDOC; S584_101_S03_da00:07.SCHDOC; S584_101_S04_da08:15.SCHDOC; S584_101_S05_da16:23.SCHDOC; S584_101_S06_da24:31.SCHDOC; S584_101_S07_da32:39.SCHDOC; S584_101_S12_daclark.SCHDOC; S584_101_S09_fpga_jo.SCHDOC; S584_101_S10_fpga_jo.SCHDOC; S584_101_S11_fpga_cvt.SCHDOC;

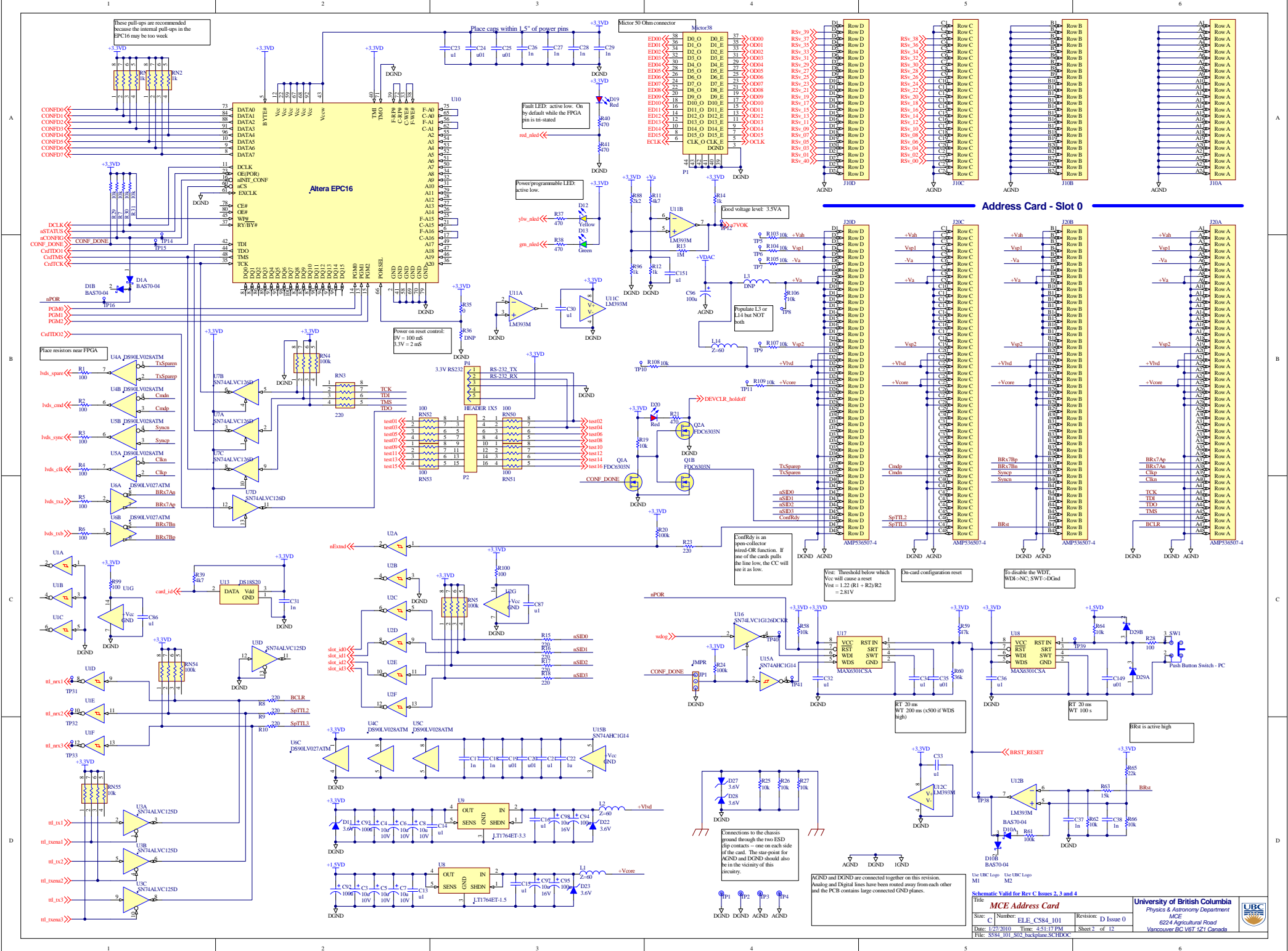

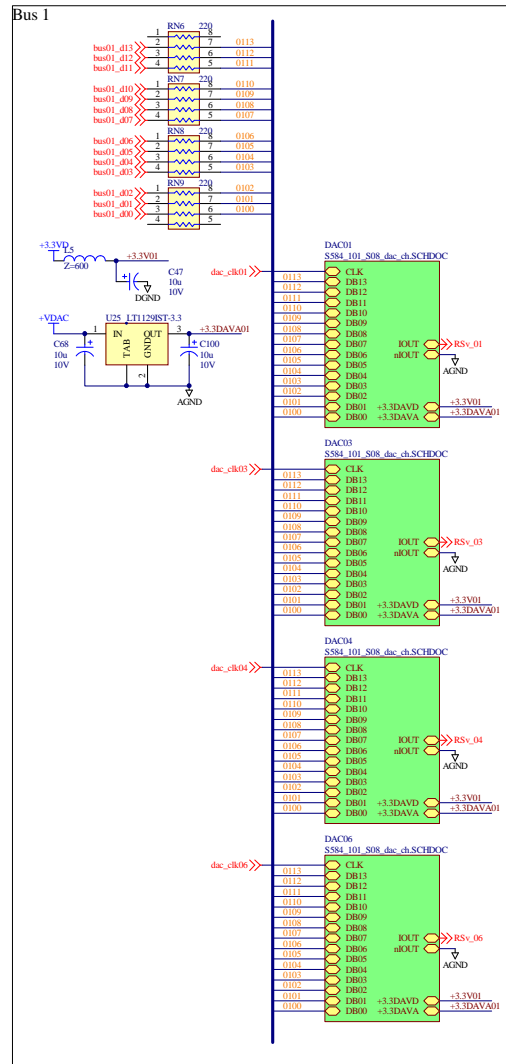

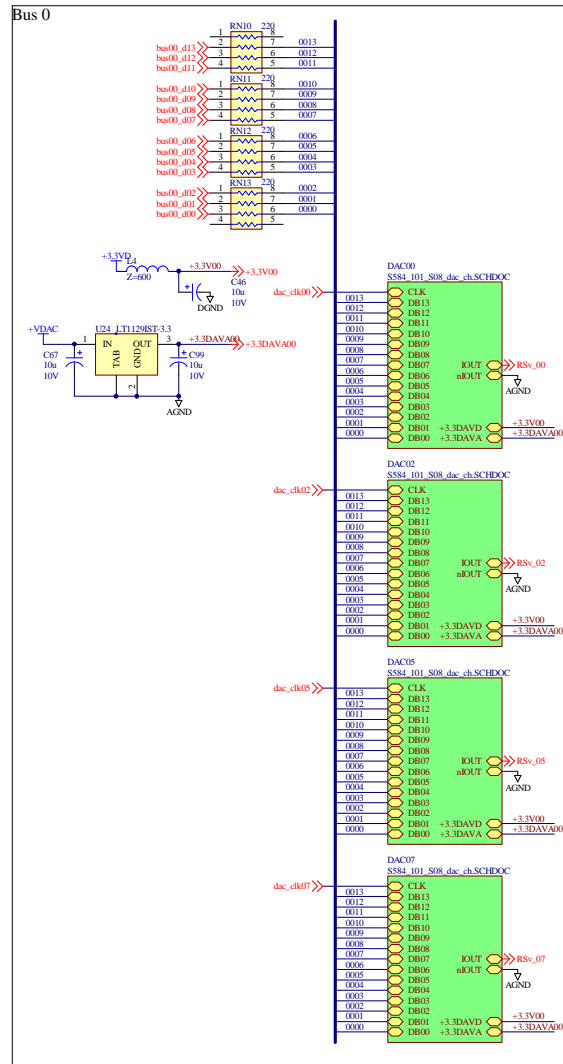

Schematic Valid for Rev C Issues 2, 3 and 4

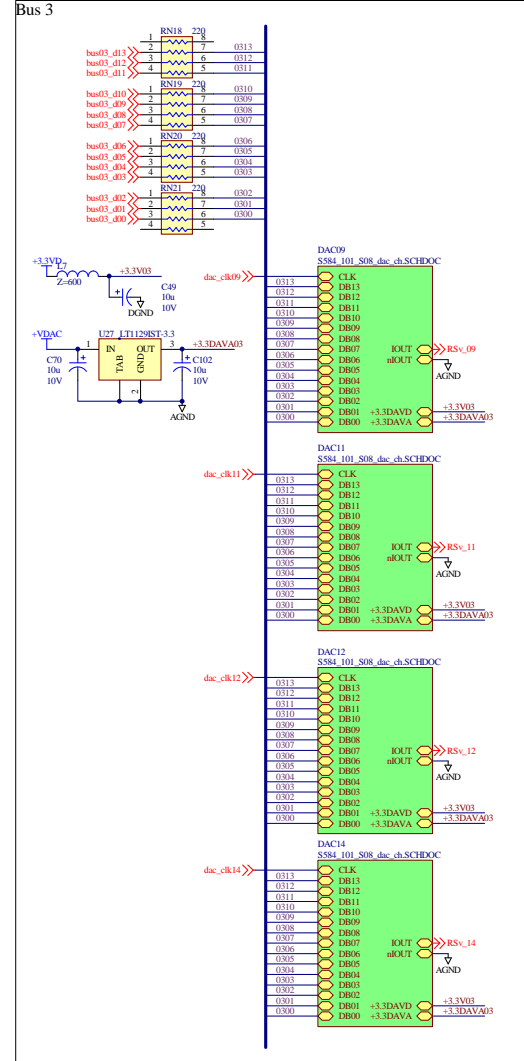
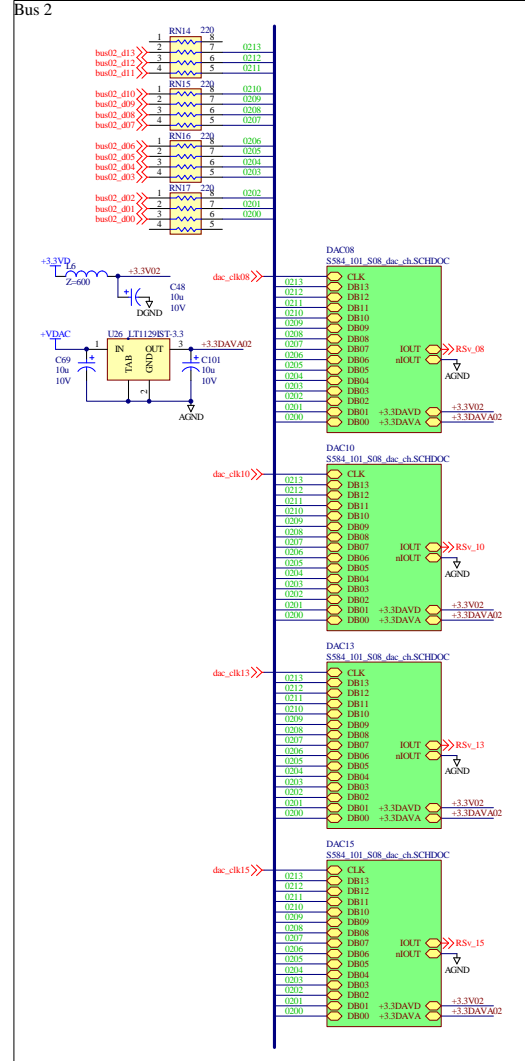

Schematic Valid for Rev C Issues 2, 3 and 4

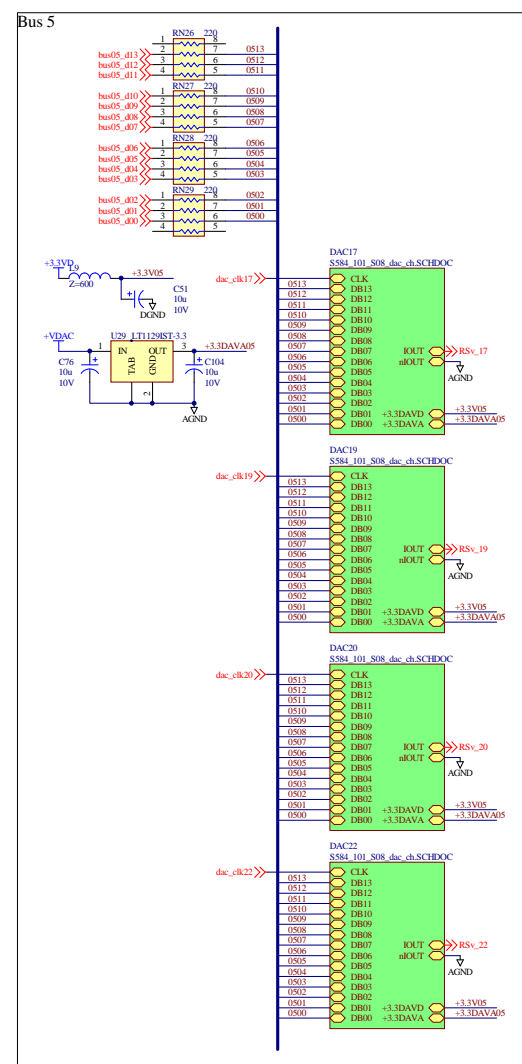
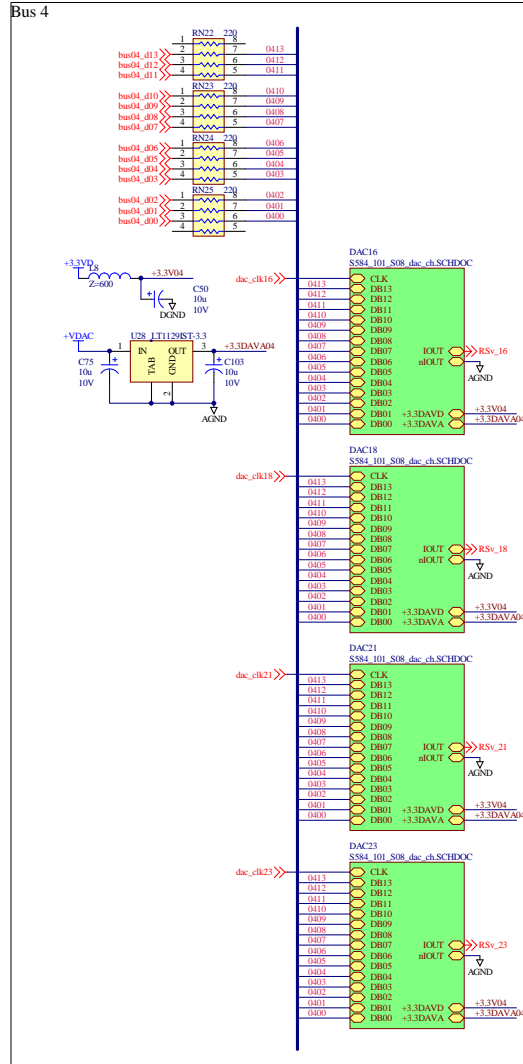

Schematic Valid for Rev C Issues 2, 3 and 4

Title: **MCE Address Card**
 Svc: C Number: ELE_CS84_101 Revision: D Issue 0
 Date: 1/27/2010 Time: 4:51:17 PM Sheet 5 of 12
 File: S884_101_S08_dac16-23.SCHDOOC

University of British Columbia
 Physics & Astronomy Department
 MCE
 6224 Agricultural Road
 Vancouver BC V6T 1Z1 Canada



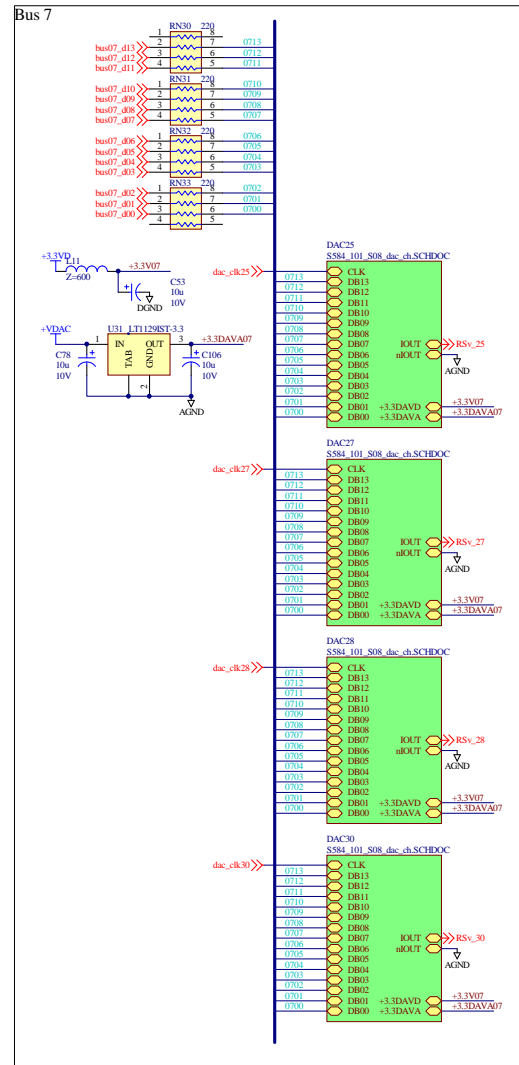
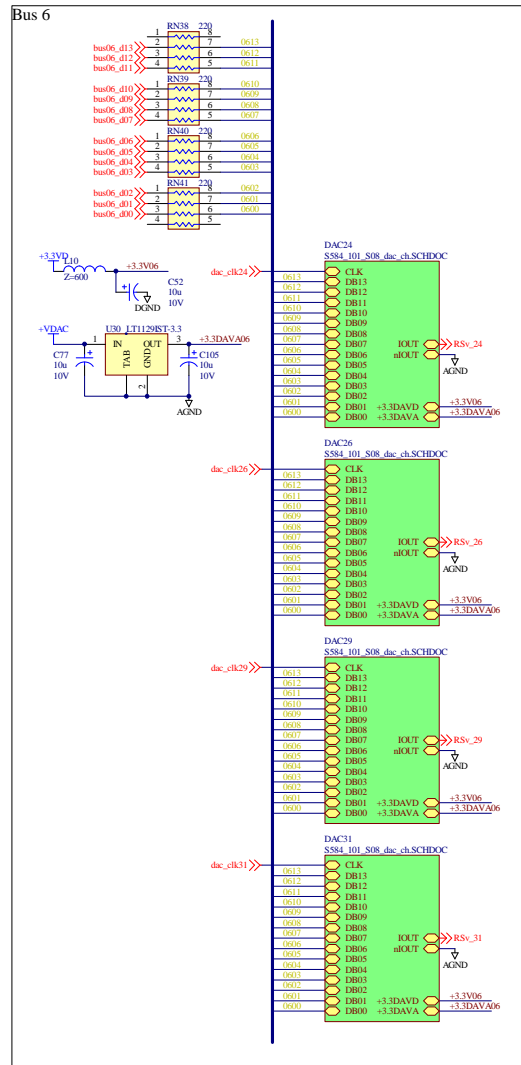

Schematic Valid for Rev C Issues 2, 3 and 4

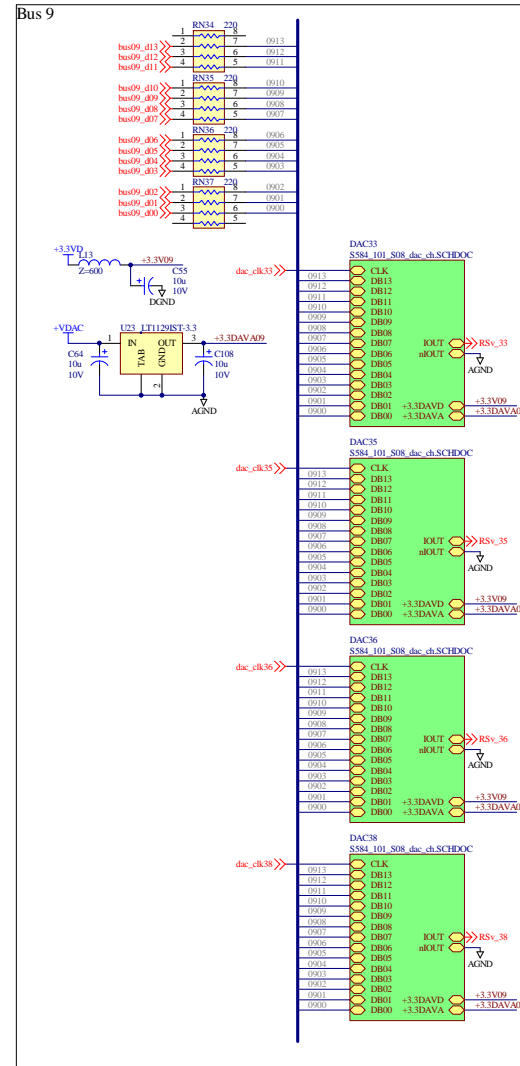
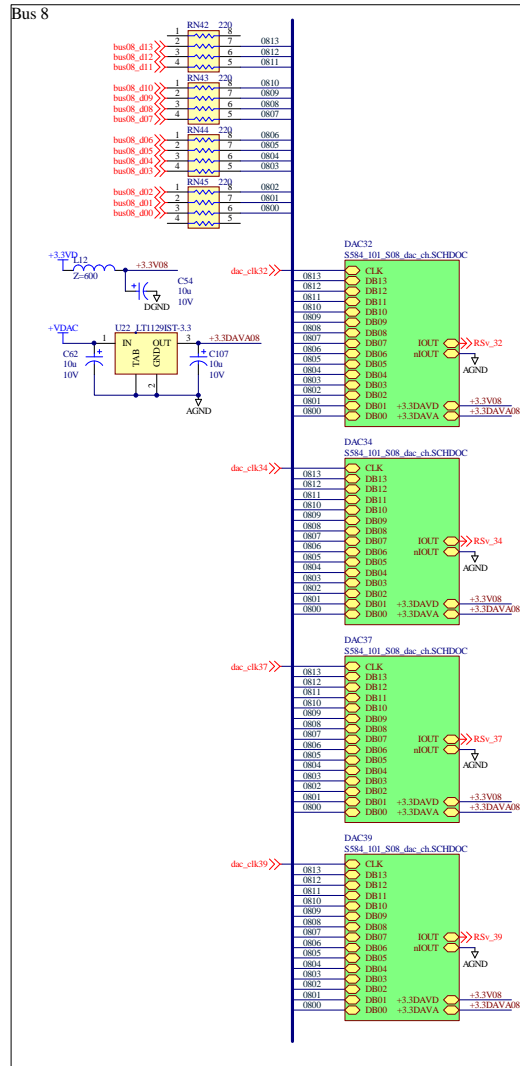

Schematic Valid for Rev C Issues 2, 3 and 4

Title: **MCE Address Card**

Rev: C Number: ELE_CS84_101 Revision: D Issue 0
 Date: 1/27/2010 Time: 4:51:17 PM Sheet 7 of 12
 File: S884_101_S07_dac32-39.SCHDOC

University of British Columbia
 Physics & Astronomy Department
 MCE
 6224 Agricultural Road
 Vancouver BC V6T 1Z1 Canada



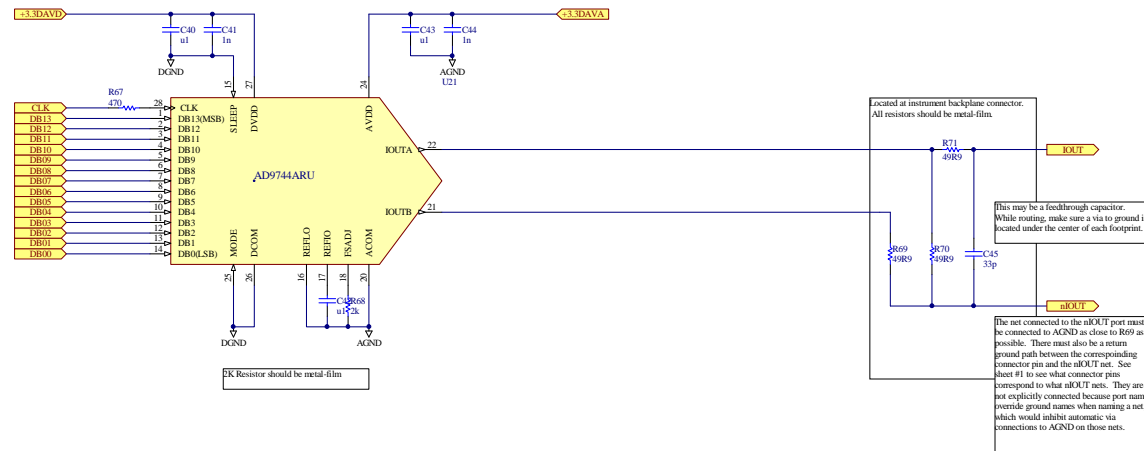

Schematic Valid for Rev C Issues 2, 3 and 4

Title: **MCE Address Card**
 Size: C Number: ELE_CS84_101 Revision: D Issue 0
 Date: 1/27/2010 Time: 4:51:17 PM Sheet 8 of 12
 File: SSSA_T01_SIB.dwg_ch3X.HDXC

University of British Columbia
 Physics & Astronomy Department
 MCE
 6224 Agricultural Road
 Vancouver BC V6T 1Z1 Canada



A

A

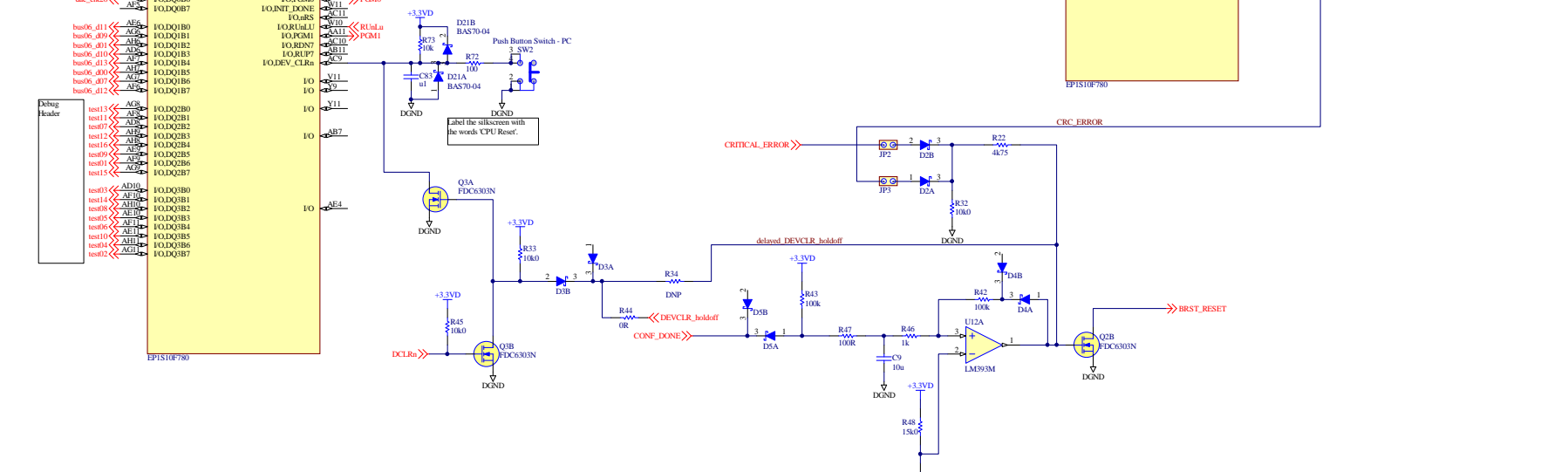

B

B

C

C

D

D

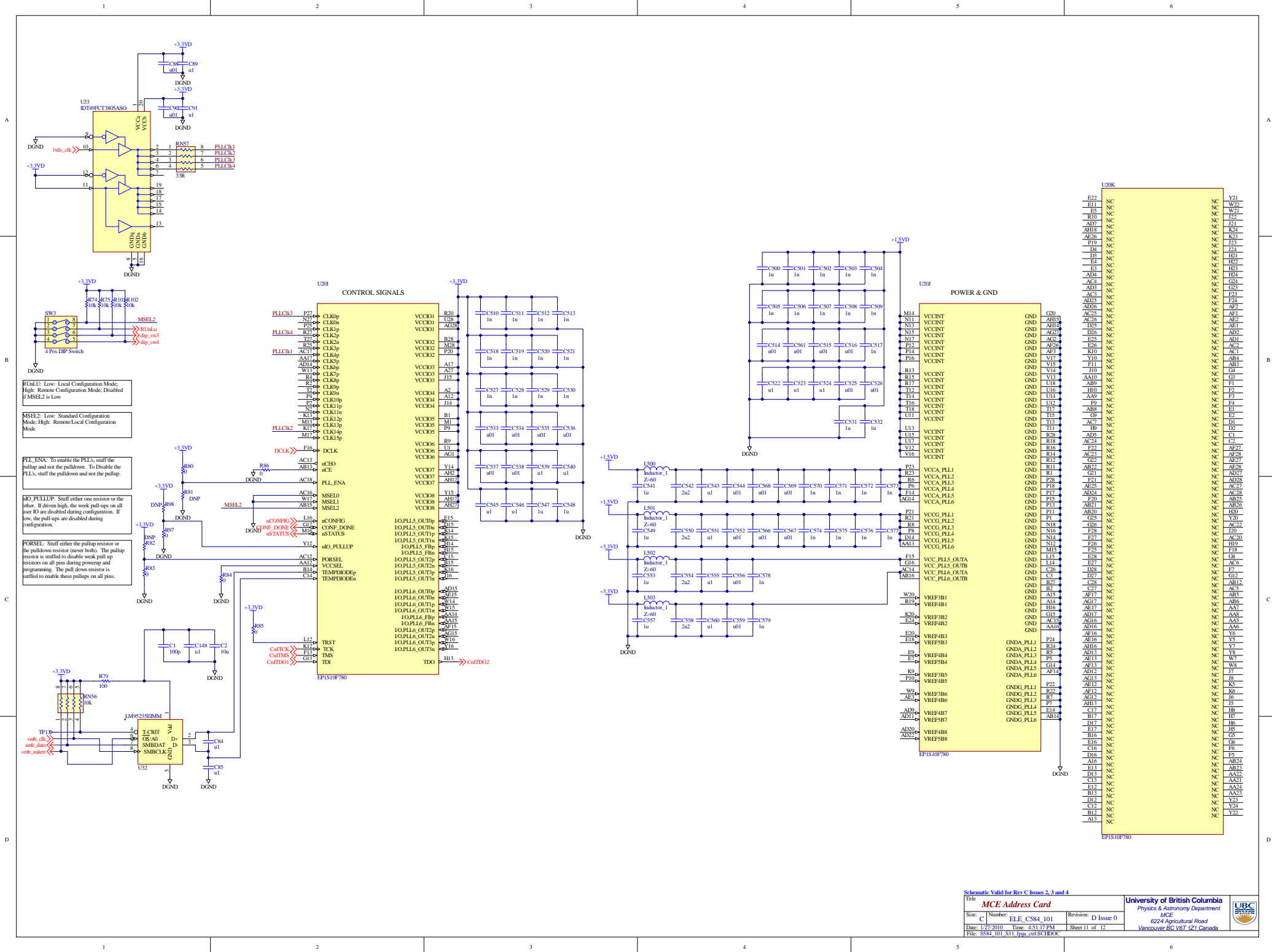

U20K	U20K	U20K
E22	NC	NC
E21	NC	NC
E5	NC	NC
R10	NC	NC
J22	NC	NC
A07	NC	NC
AH18	NC	NC
A04	NC	NC
AE26	NC	NC
F19	NC	NC
D4	NC	NC
D3	NC	NC
H1	NC	NC
H2	NC	NC
E3	NC	NC
AD4	NC	NC
AD3	NC	NC
AD25	NC	NC
AD26	NC	NC
AC25	NC	NC
AE36	NC	NC
D25	NC	NC
AD29	NC	NC
D26	NC	NC
E25	NC	NC
E26	NC	NC
K10	NC	NC
Y17	NC	NC
Y10	NC	NC
F11	NC	NC
T10	NC	NC
AA10	NC	NC
AB9	NC	NC
H10	NC	NC
AA9	NC	NC
U14	NC	NC
U12	NC	NC
U11	NC	NC
U10	NC	NC
U9	NC	NC
U8	NC	NC
U7	NC	NC
U6	NC	NC
U5	NC	NC
U4	NC	NC
U3	NC	NC
U2	NC	NC
U1	NC	NC
U0	NC	NC
U23	NC	NC
U22	NC	NC
U21	NC	NC
U20	NC	NC
U19	NC	NC
U18	NC	NC
U17	NC	NC
U16	NC	NC
U15	NC	NC
U14	NC	NC
U13	NC	NC
U12	NC	NC
U11	NC	NC
U10	NC	NC
U9	NC	NC
U8	NC	NC
U7	NC	NC
U6	NC	NC
U5	NC	NC
U4	NC	NC
U3	NC	NC
U2	NC	NC
U1	NC	NC
U0	NC	NC
U23	NC	NC
U22	NC	NC
U21	NC	NC
U20	NC	NC
U19	NC	NC
U18	NC	NC
U17	NC	NC
U16	NC	NC
U15	NC	NC
U14	NC	NC
U13	NC	NC
U12	NC	NC
U11	NC	NC
U10	NC	NC
U9	NC	NC
U8	NC	NC
U7	NC	NC
U6	NC	NC
U5	NC	NC
U4	NC	NC
U3	NC	NC
U2	NC	NC
U1	NC	NC
U0	NC	NC
U23	NC	NC
U22	NC	NC
U21	NC	NC
U20	NC	NC
U19	NC	NC
U18	NC	NC
U17	NC	NC
U16	NC	NC
U15	NC	NC
U14	NC	NC
U13	NC	NC
U12	NC	NC
U11	NC	NC
U10	NC	NC
U9	NC	NC
U8	NC	NC
U7	NC	NC
U6	NC	NC
U5	NC	NC
U4	NC	NC
U3	NC	NC
U2	NC	NC
U1	NC	NC
U0	NC	NC
U23	NC	NC
U22	NC	NC
U21	NC	NC
U20	NC	NC
U19	NC	NC
U18	NC	NC
U17	NC	NC
U16	NC	NC
U15	NC	NC
U14	NC	NC
U13	NC	NC
U12	NC	NC
U11	NC	NC
U10	NC	NC
U9	NC	NC
U8	NC	NC
U7	NC	NC
U6	NC	NC
U5	NC	NC
U4	NC	NC
U3	NC	NC
U2	NC	NC
U1	NC	NC
U0	NC	NC
U23	NC	NC
U22	NC	NC
U21	NC	NC
U20	NC	NC
U19	NC	NC
U18	NC	NC
U17	NC	NC
U16	NC	NC
U15	NC	NC
U14	NC	NC
U13	NC	NC
U12	NC	NC
U11	NC	NC
U10	NC	NC
U9	NC	NC
U8	NC	NC
U7	NC	NC
U6	NC	NC
U5	NC	NC
U4	NC	NC
U3	NC	NC
U2	NC	NC
U1	NC	NC
U0	NC	NC
U23	NC	NC
U22	NC	NC
U21	NC	NC
U20	NC	NC
U19	NC	NC
U18	NC	NC
U17	NC	NC
U16	NC	NC
U15	NC	NC
U14	NC	NC
U13	NC	NC
U12	NC	NC
U11	NC	NC
U10	NC	NC
U9	NC	NC
U8	NC	NC
U7	NC	NC
U6	NC	NC
U5	NC	NC
U4	NC	NC
U3	NC	NC
U2	NC	NC
U1	NC	NC
U0	NC	NC
U23	NC	NC
U22	NC	NC
U21	NC	NC
U20	NC	NC
U19	NC	NC
U18	NC	NC
U17	NC	NC
U16	NC	NC
U15	NC	NC
U14	NC	NC
U13	NC	NC
U12	NC	NC
U11	NC	NC
U10	NC	NC
U9	NC	NC
U8	NC	NC
U7	NC	NC
U6	NC	NC
U5	NC	NC
U4	NC	NC
U3	NC	NC
U2	NC	NC
U1	NC	NC
U0	NC	NC
U23	NC	NC
U22	NC	NC
U21	NC	NC
U20	NC	NC
U19	NC	NC
U18	NC	NC
U17	NC	NC
U16	NC	NC
U15	NC	NC
U14	NC	NC
U13	NC	NC
U12	NC	NC
U11	NC	NC
U10	NC	NC
U9	NC	NC
U8	NC	NC
U7	NC	NC
U6	NC	NC
U5	NC	NC
U4	NC	NC
U3	NC	NC
U2	NC	NC
U1	NC	NC
U0	NC	NC
U23	NC	NC
U22	NC	NC
U21	NC	NC
U20	NC	NC
U19	NC	NC
U18	NC	NC
U17	NC	NC
U16	NC	NC
U15	NC	NC
U14	NC	NC
U13	NC	NC
U12	NC	NC
U11	NC	NC
U10	NC	NC
U9	NC	NC
U8	NC	NC
U7	NC	NC
U6	NC	NC
U5	NC	NC
U4	NC	NC
U3	NC	NC
U2	NC	NC
U1	NC	NC
U0	NC	NC
U23	NC	NC
U22	NC	NC
U21	NC	NC
U20	NC	NC
U19	NC	NC
U18	NC	NC
U17	NC	NC
U16	NC	NC
U15	NC	NC
U14	NC	NC
U13	NC	NC
U12	NC	NC
U11	NC	NC
U10	NC	NC
U9	NC	NC
U8	NC	NC
U7	NC	NC
U6	NC	NC
U5	NC	NC
U4	NC	NC
U3	NC	NC
U2	NC	NC
U1	NC	NC
U0	NC	NC
U23	NC	NC
U22	NC	NC
U21	NC	NC
U20	NC	NC
U19	NC	NC
U18	NC	NC
U17	NC	NC
U16	NC	NC
U15	NC	NC
U14	NC	NC
U13	NC	NC
U12	NC	NC
U11	NC	NC
U10	NC	NC
U9	NC	NC
U8	NC	NC
U7	NC	NC
U6	NC	NC
U5	NC	NC
U4	NC	NC
U3	NC	NC
U2	NC	NC
U1	NC	NC
U0	NC	NC

