



In many ways the revolution accomplished by Einstein is the most staggering intellectual achievement of all time, at least in science. In contrast to Newton's work, Einstein's theory of gravitation came not because it was demanded by observation, but because it was demanded by Einstein, who was looking for a general theory to understand spacetime, gravity, and all fields living in spacetime. The extraordinary result he found was that spacetime is itself a field, to be unified with gravity. He was never able to unify this field with the other fields around, and the search for such a unification is still with us. He also made many other fundamental contributions to physics, as we will see later.

A. Einstein (1879-1955) in California (mid-1930's)

# SPACETIME: RODS & CLOCKS

As we already learned in discussing Newton, it is not entirely straightforward to define space and time. By the 19<sup>th</sup> century physicists were used to doing this by imagining some network of rods and clocks, giving standard measures of length and time. In one's imagination one could then assume that each POINT in space and time was defined by an imaginary lattice of rods & clocks. It was universally assumed that

- (i) space was Euclidean
- (ii) time and space were separate.

This meant, amongst many other things, that relative velocities added to each other. This meant that if, eg., person (A) measured light to have a velocity  $c$  in some direction, then another person (B) moving in the same direction at a velocity  $v$  relative to (A) would see the light moving at a velocity  $c' = c - v$ .

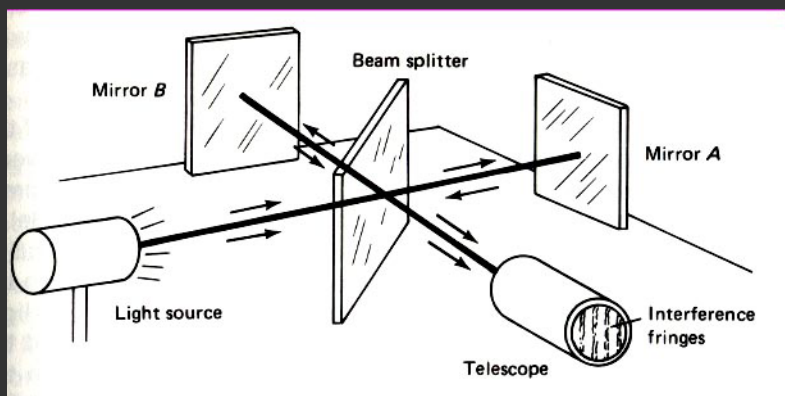
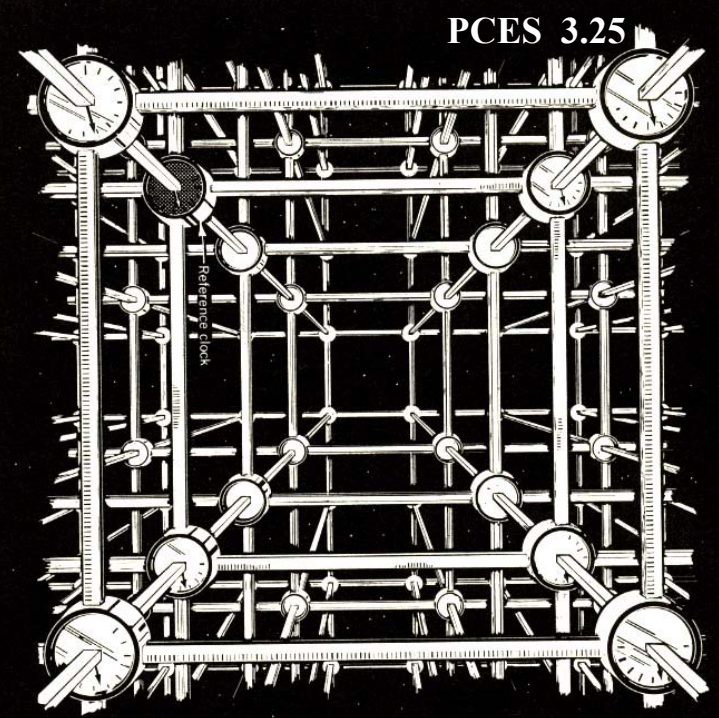

Unfortunately this led to problems- it conflicted with Maxwell's equations, for which any observer would see light moving at  $c$  in any direction, no matter the velocity of the observer! The famous Michelson-Morley experiment (1895) showed the earth always moved at a velocity  $c$  relative to starlight- so something was wrong!

# SPECIAL RELATIVITY

Various people contributed to what is now called the theory of “Special Relativity”, but the overall framework and many of the key results were in Einstein’s 1905 paper. Einstein started from a simple basic principle, the **PRINCIPLE of RELATIVITY**:

The laws of physics are the same in all inertial frames

As noticed by Einstein, this forced a choice between Maxwell’s theory and Newton’s laws- according to Newton velocities were additive, but in Maxwell’s theory, the velocity of light was the same in any reference frame. Einstein plumped for Maxwell (without actually knowing about the Michelson-Morley experiment).

The fact that velocities are not additive means a fundamental change in our understanding of space and time- the length of an object depends on what reference frame it is measured in, and likewise for time intervals. The precise (ie., mathematical) description of this is well beyond the course.

There are, however, things that do not change from one reference frame to another- these **INVARIANTS** are in some sense more “real” than those things which depend on the reference frame. The most important is the **INTERVAL s**, which is defined by

$$s^2 = c^2t^2 - l^2$$

which tells us that space & time cannot be separated, and that the common sense idea, that distances **l** and time intervals **t** are absolute, is simply wrong.

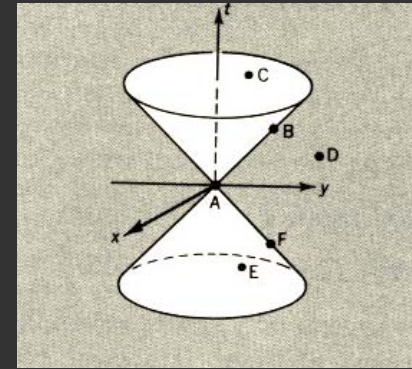

Coordinates in spacetime (2-d space)

# NON-EUCLIDEAN GEOMETRY

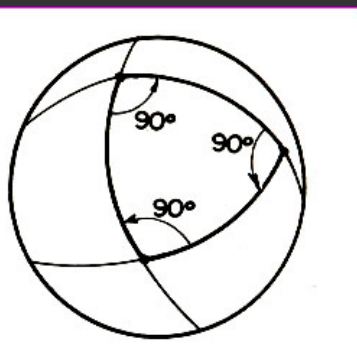

Geometry is the branch of mathematics dealing with the relationship between points, lines, angles, etc.; these define the structure of the space they exist in. To see how non-Euclidean geometry could work, imagine being confined to 2 dimensions- with no awareness at all of any higher dimensions.

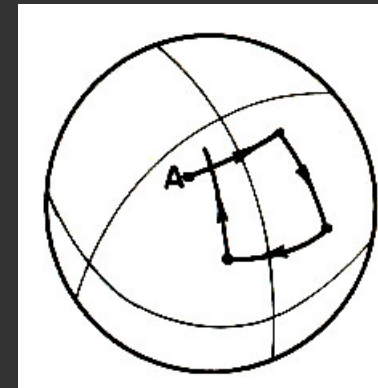

Now suppose we find that (i) the angles in a triangle don't add up to  $180^\circ$ ; that (ii) If one tries to draw a square by joining 4 equal lines with right angles, then the lines don't close up; and that (iii) if we measure the area of a circle, it is not proportional to the square of the radius. How can this be explained?

Since we live in a higher dimension, the explanation is very easy for us to see- the 2-dimensional space in which these results are found is **CURVED**. For a being only aware of the 2-d space, the internal geometry of the space is seen as **NON-EUCLIDEAN**. Notice that for very small objects (small squares, triangles, circles, etc), the geometry does appear Euclidean- we only get deviations for large objects. We say that the geometry is **LOCALLY** Euclidean (or "flat"), but **GLOBALLY** non-Euclidean.

In General Relativity, it is 4-dimensional **SPACETIME** that has a non-Euclidean geometry...

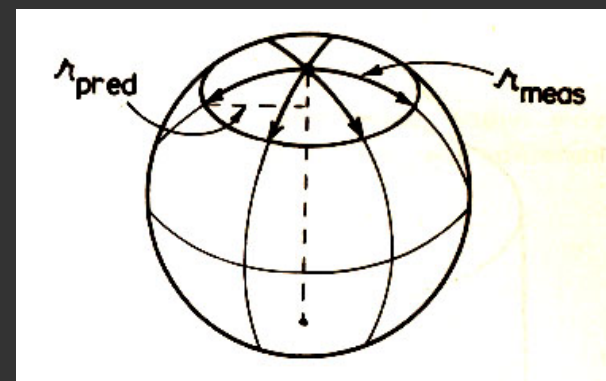

# The PRINCIPLE of EQUIVALENCE

A simple thought experiment (“gedanken” experiment), of Einstein, has someone inside an elevator or closed box. The point is that from inside, one cannot distinguish a box in an inertial frame from one falling in a uniform gravitational field. This can be used as the starting point of a far-reaching argument. Notice first that this implies the identity of gravitational and inertial mass. The inertial mass is the mass which is being accelerated, ie., the mass  $m$  appearing in  $F = ma$ , which we can call  $m_i$ . The gravitational mass is the mass which measures how strongly the system feels a gravitational field- remember that if our system is being attracted by some other mass  $M$ , then the force on it is

$$F = \frac{GM}{r} m_G$$

where the mass here we call  $m_G$ , the gravitational mass- notice that  $m_G$  is like a “gravitational charge”, analogous to the electrical charge in Coulomb’s law. To say that these two masses are the same “mass”  $m$  is the point at issue.

This equivalence has been the subject of many experiments since the first one of Eotvos in 1920- always with the result that  $m_i = m_G$ , within experimental error.

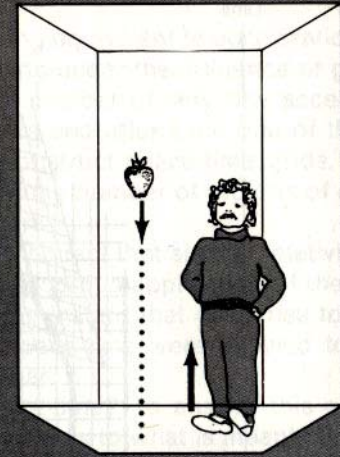

Eotvos experiment ( )

# GENERAL RELATIVITY

There is however one way to distinguish gravitational from inertial forces - gravity causes TIDAL forces, because the gravitational field is inevitably non-uniform. At right we see how the field near a body like the earth affects a fluid drop (the earth is below the picture); we assume these spheres are falling in the field, but the field isn't uniform (in an inertial frame the drops would all remain spherical).

One can in a simplified way think of the strength of these tidal forces as being proportional to the spacetime curvature (though to completely specify this we need more information). The essential content of Einstein's theory- which took him 8 years to find after formulating the principle of equivalence- is that the curvature at any point is proportional to the "stress-energy tensor"

(roughly, the energy density- and mass is counted here as energy via  $E = mc^2$ ). I don't write any equations here!

The 1<sup>st</sup> success of the theory came immediately- it explained the slow precession of Mercury's orbit (the slow rotation in its orientation), shown at left.

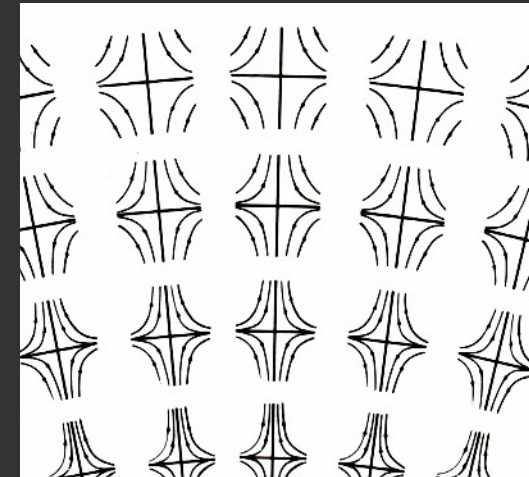
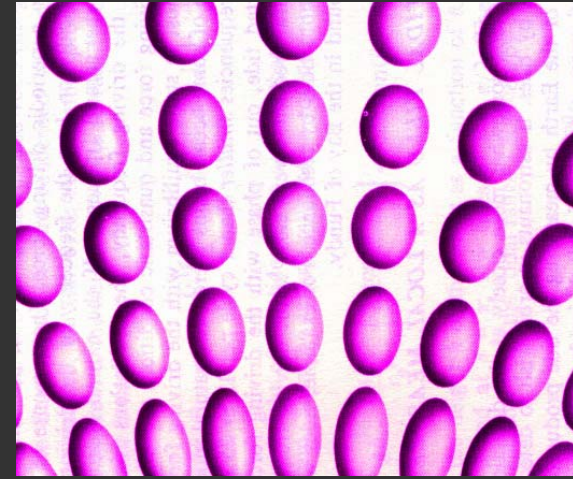
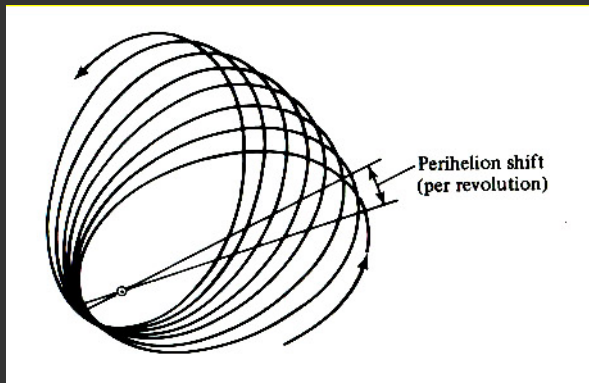

Tidal forces near a massive body- force lines on a drop shown below.

# GRAVITATIONAL LIGHT-BENDING

One of the simplest tests of general relativity (and the one whose spectacular success in 1919 made Einstein famous) is the bending of light by the distorted spacetime around any massive object. This bending is NOT the same as one would calculate by just assuming the light to be pulled sideways by the sun's gravity as it passes—hence the interest of the test. Under the direction Sir Arthur Eddington, the Royal Society sent 2 expeditions (to the Brazilian island of Sobral, and to Principe) to measure the displacement of stars near the sun, during a solar eclipse. The confirmation of Einstein's predictions was given in a historic meeting in London, where they were announced as the greatest advance in science since Newton. This gave Einstein worldwide celebrity. All subsequent tests (now done with radio waves) give agreement with theory. However, this was a

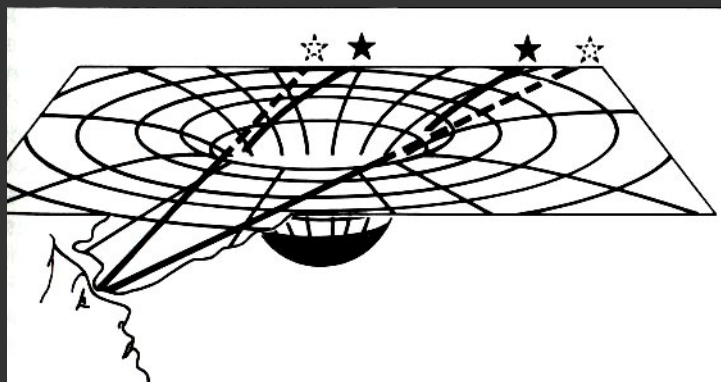
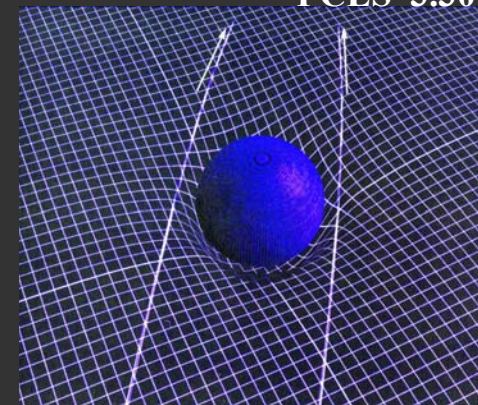

**Deflection of starlight near the sun**

“weak field” test. It was easy in 1919 to think that Einstein's theory was of little practical interest.

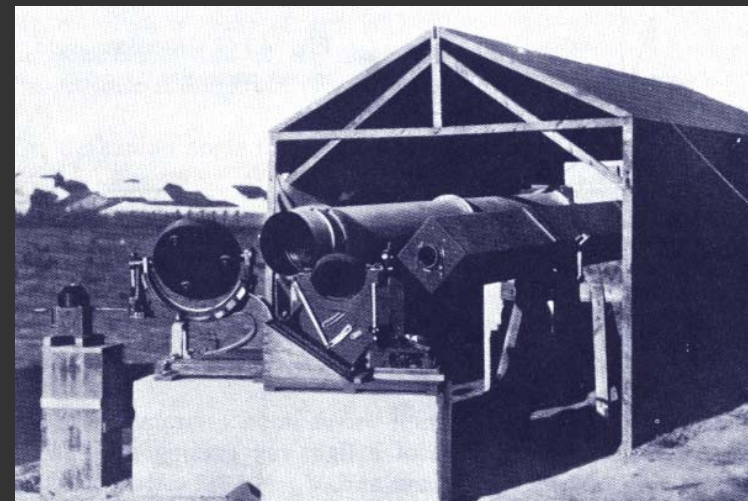

**The instruments used at Sobral in 1919.**